

*An Online PDH Course
brought to you by
CEDengineering.com*

Tef ct 'Hwpf co gpvcu

Course No: G27/236"
Credit: 7 PDH

Gkg'Vcy kn'ROGO'NGGF "CR



Continuing Education and Development, Inc.

P: (877) 322-5800
info@cedengineering.com

This course was adapted from the “Module 18 - Radar Principles” of the Naval Education and Training Materials, Publication No. NAVEDTRA 14190A, Electricity and Electronic Training Series, which is in the public domain.

Sailor's Creed

“I am a United States Sailor.

I will support and defend the
Constitution of the United States of
America and I will obey the orders of those
appointed over me.

I represent the fighting spirit of the Navy
and those who have gone before me to
defend freedom and democracy around the
world.

I proudly serve my country's Navy combat
team with honor, courage and commitment.

I am committed to excellence and the fair
treatment of all.”

TABLE OF CONTENTS

CHAPTER	PAGE
1 Radar Fundamentals.....	1-1
2 Radar Subsystems.....	2-1
3 Radar Indicators.....	3-1
4 Radar Systems Maintenance.....	4-1
 APPENDIX	
A Glossary.....	A-1

NAVY ELECTRICITY AND ELECTRONICS TRAINING SERIES

The Navy Electricity and Electronics Training Series (NEETS) was developed for use by personnel in many electrical and electronic-related Navy ratings. Written by, and with the advice of, senior technicians in these ratings, this series provides beginners with fundamental electrical and electronic concepts through self-study. The presentation of this series is not oriented to any specific rating structure, but is divided into modules containing related information organized into traditional paths of instruction.

The series is designed to give small amounts of information that can be easily digested before advancing further into the more complex material. For a student just becoming acquainted with electricity or electronics, it is highly recommended that the modules be studied in their suggested sequence.

Considerable emphasis has been placed on illustrations to provide a maximum amount of information. In some instances, knowledge of basic algebra may be required.

Course descriptions and ordering information may be found at <https://www.netc.navy.mil> then click on the Programs tab, then select the Nonresident Training Courses from the list.

Throughout the text of this course and while using technical manuals associated with the equipment you will be working on, you will find the below notations at the end of some paragraphs. The notations are used to emphasize that safety hazards exist and care must be taken or observed.

WARNING

AN OPERATING PROCEDURE, PRACTICE, OR CONDITION, ETC., WHICH MAY RESULT IN INJURY OR DEATH IF NOT CAREFULLY OBSERVED OR FOLLOWED.

CAUTION

AN OPERATING PROCEDURE, PRACTICE, OR CONDITION, ETC., WHICH MAY RESULT IN DAMAGE TO EQUIPMENT IF NOT CAREFULLY OBSERVED OR FOLLOWED.

NOTE

An operating procedure, practice, or condition, etc., which is essential to emphasize.

NEETS MODULE 18-Radar Principles

1 RADAR FUNDAMENTALS

LEARNING OBJECTIVES

After you finish this chapter, you should be able to do the following:

1. Define range, bearing, and altitude as they relate to a radar system.
2. Discuss how pulse width, peak power, and beam width affect radar performance.
3. Describe the factors that contribute to or detract from radar accuracy.
4. Using a block diagram, describe the basic function, principles of operation, and interrelationships of the basic units of a radar system.
5. Explain the various ways in which radar systems are classified, including the standard Army/Navy classification system.
6. Explain the basic operation of cw, pulse, and Doppler radar systems.

1.1 INTRODUCTION TO RADAR FUNDAMENTALS

The term RADAR is common in today's everyday language. You probably use it yourself when referring to a method of recording the speed of a moving object. The term *Radar* is an acronym made up of the words radio detection and ranging. The term is used to refer to electronic equipment that detect the presence, direction, height, and distance of objects by using reflected electromagnetic energy. Electromagnetic energy of the frequency used for radar is unaffected by darkness and also penetrates weather to some degree, depending on frequency. It permits radar systems to determine the positions of ships, planes, and land masses that are invisible to the naked eye because of distance, darkness, or weather.

The development of radar into the highly complex systems in use today represents the accumulated developments of many people and nations. The general principles of radar have been known for a long time, but many electronics discoveries were necessary before a useful radar system could be developed. World War II provided a strong incentive to develop practical radar, and early versions were in use soon after the war began. Radar technology has improved in the years since the war. We now have radar systems that are smaller, more efficient, and better than those early versions.

Modern radar systems are used for early detection of surface or air objects and provide extremely accurate information on distance, direction, height, and speed of the objects. Radar is also used to guide missiles to targets and direct the firing of gun systems. Other types of radar provide long-distance surveillance and navigation information.

NEETS MODULE 18-Radar Principles

1.2 BASIC RADAR CONCEPTS

The electronics principle on which radar operates is very similar to the principle of sound-wave reflection. If you shout in the direction of a sound-reflecting object (like a rocky canyon or cave), you will hear an echo. If you know the speed of sound in air, you can then estimate the distance and general direction of the object. The time required for a return echo can be roughly converted to distance if the speed of sound is known. Radar uses electromagnetic energy pulses in much the same way, as shown in figure 1-1. The radio-frequency (rf) energy is transmitted to and reflects from the reflecting object. A small portion of the energy is reflected and returns to the radar set. This returned energy is called an ECHO, just as it is in sound terminology. Radar sets use the echo to determine the direction and distance of the reflecting object.

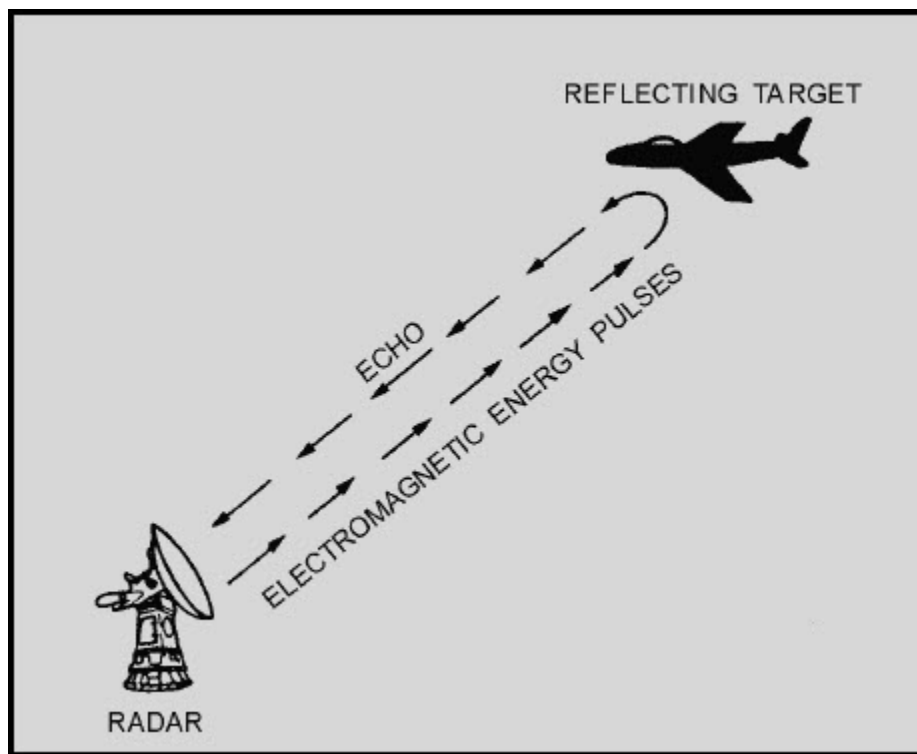

Figure 1-1 Radar echo

NOTE: The terms TARGET, RETURN, ECHO, CONTACT, OBJECT, and REFLECTING OBJECT are used interchangeably throughout this module to indicate a surface or airborne object that has been detected by a radar system.

NEETS MODULE 18-Radar Principles

Radar systems also have some characteristics in common with telescopes. Both provide only a limited field of view and require reference coordinate systems to define the positions of detected objects. If you describe the location of an object as you see it through a telescope, you will most likely refer to prominent features of the landscape. Radar requires a more precise reference system. Radar surface angular measurements are normally made in a clockwise direction from TRUE NORTH, as shown in figure 1-2, or from the heading line of a ship or aircraft. The surface of the earth is represented by an imaginary flat plane, tangent (or parallel) to the earth's surface at that location. This plane is referred to as the HORIZONTAL PLANE. All angles in the up direction are measured in a second imaginary plane that is perpendicular to the horizontal plane.

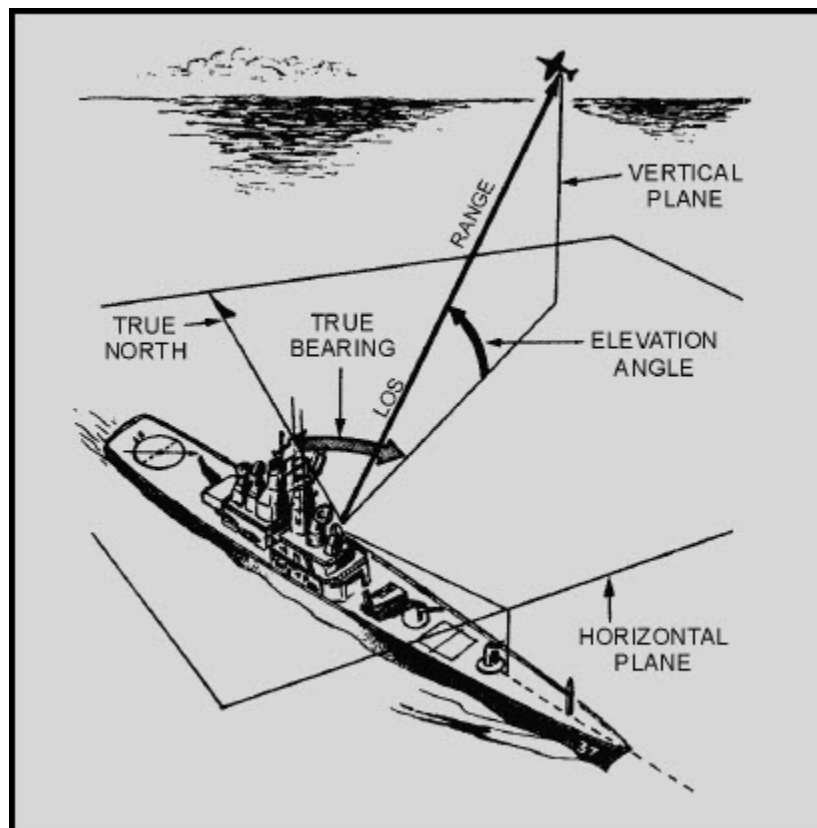

Figure 1-2 Radar reference coordinates

This second plane is called the VERTICAL PLANE. The radar location is the center of this coordinate system. The line from the radar set directly to the object is referred to as the LINE OF SIGHT (LOS). The length of this line is called RANGE. The angle between the horizontal plane and the LOS is the ELEVATION ANGLE. The angle measured clockwise from true north in the horizontal plane is called the TRUE BEARING or AZIMUTH angle. These three coordinates of range, bearing, and elevation describe the location of an object with respect to the antenna.

NEETS MODULE 18-Radar Principles

Q1. Radar surface-angular measurements are referenced to true north and measured in what plane?

Q2. The distance from a radar set to a target measured along the line of sight is identified by what term?

1.2.1 Range

Radar measurement of range, or distance, is made possible because of the properties of radiated electromagnetic energy. This energy normally travels through space in a straight line, at a constant speed, and will vary only slightly because of atmospheric and weather conditions. The effects atmosphere and weather have on this energy will be discussed later in this chapter; however, for this discussion on determining range, these effects will be temporarily ignored.

Electromagnetic energy travels through air at approximately the speed of light, which is 186,000 STATUTE MILES per second. The Navy uses NAUTICAL MILES to calculate distances; 186,000 statute miles is approximately 162,000 nautical miles. While the distance of the statute mile is approximately 5,280 feet, the distance for a nautical mile is approximately 6,080 feet.

Radar timing is usually expressed in microseconds. To relate radar timing to distances traveled by radar energy, you should know that radiated energy from a radar set travels at approximately 984 feet per microsecond. With the knowledge that a nautical mile is approximately 6,080 feet, we can figure the approximate time required for radar energy to travel one nautical mile using the following calculation:

$$\begin{aligned} &\text{time for energy to travel one nautical mile} \\ &= \frac{6,080 \text{ feet}}{984 \text{ feet per microsecond}} \\ &= 6.18 \text{ microseconds (approx.)} \end{aligned}$$

NEETS MODULE 18-Radar Principles

The same answer can be obtained using yards instead of feet. In the following calculation, the 6,080 foot approximation of a nautical mile is converted to 2,027 yards and energy speed is changed from 984 feet to 328 yards per microsecond:

$$\begin{aligned}
 &\text{time for energy} \\
 &\text{to travel one} \quad = \frac{2,027 \text{ yards}}{328 \text{ yards per microsecond}} \\
 &\text{nautical mile} \\
 &= 6.18 \text{ microseconds} \\
 &\quad \text{(approx.)}
 \end{aligned}$$

A pulse-type radar set transmits a short burst of electromagnetic energy. Target range is determined by measuring elapsed time while the pulse travels to and returns from the target. Because two-way travel is involved, a total time of 12.36 (6.18 x 2) microseconds per nautical mile will elapse between the start of the pulse from the antenna and its return to the antenna from a target. This 12.36 microsecond time interval is sometimes referred to as a RADAR MILE, RADAR NAUTICAL MILE, or NAUTICAL RADAR MILE. The range in nautical miles to an object can be found by measuring the elapsed time during a *round trip* of a radar pulse and dividing this quantity by 12.36. In equation form, this is:

$$\text{range} = \frac{\text{elapsed time}}{12.36 \text{ microseconds per nautical mile}}$$

NEETS MODULE 18-Radar Principles

For example, if the elapsed time for an echo is 62 microseconds, then the distance is 5 miles, as shown in the following calculation:

$$\begin{aligned} \text{range} &= \frac{\text{elapsed time}}{12.36 \text{ microseconds per nautical mile}} \\ &= \frac{62 \text{ microseconds}}{12.36 \text{ microseconds per nautical mile}} \\ &= 5 \text{ nautical miles (approx.)} \end{aligned}$$

NOTE: Unless otherwise stated all distances will be expressed as nautical miles throughout this module.

1.2.1.1 Minimum Range

Recall from NEETS, Module 11, *Microwave Principles*, that the DUPLEXER alternately switches the antenna between the transmitter and receiver so that only one antenna need be used. This switching is necessary because the high-power pulses of the transmitter would destroy the receiver if energy were allowed to enter the receiver. As you probably already realize, timing of this switching action is critical to the operation of the radar system. What you may not realize is that the minimum range ability of the radar system is also affected by this timing. The two most important times in this action are PULSE WIDTH and RECOVERY TIME.

This timing action must be such that during the transmitted pulse (pulse width), only the transmitter can be connected to the antenna. Immediately after the pulse is transmitted, the antenna must be reconnected to the receiver.

The leading edge of the transmitted pulse causes the duplexer to align the antenna to the transmitter. This action is essentially instantaneous. At the end of the transmitted pulse, the trailing edge of the pulse causes the duplexer to line up the antenna with the receiver; however, this action is not instantaneous. A small amount of time elapses at this point that is referred to as recovery time.

NEETS MODULE 18-Radar Principles

Therefore, the total time in which the receiver is unable to receive the reflected pulse is equal to the pulse width plus the recovery time. Note that any reflected pulses from close targets returning before the receiver is connected to the antenna will be undetected. The minimum range, in yards, at which a target can be detected is determined using the following formula (pulse width and recovery time are expressed in microseconds or fractions of microseconds):

$$\text{minimum range} = \frac{\text{pulse width} + \text{recovery time}}{2} \times 328 \text{ yards}$$

or

$$\text{minimum range} = (\text{pulse width} + \text{recovery time}) \times 164 \text{ yds}$$

For example, minimum range for a radar system with a pulse width of 25 microseconds and a recovery time of 0.1 microseconds is figured as follows:

$$\begin{aligned} \text{minimum range} &= (25 + 0.1) \times 164 \text{ yards} \\ &= 25.1 \times 164 \text{ yards} \\ &= 4,116 \text{ yards (approximate)} \end{aligned}$$

Most modern radar systems are designed with such small recovery times that this figure can often be ignored when figuring minimum range.

1.2.1.2 Maximum Range

The maximum range of a pulse radar system depends upon CARRIER FREQUENCY, PEAK POWER of the transmitted pulse, PULSE-REPETITION FREQUENCY (prf) or PULSE REPETITION RATE (prr), and RECEIVER SENSITIVITY with prf as the primary limiting factor. The peak power of the pulse determines what maximum range the pulse can travel to a target and still return a usable echo. A usable echo is the smallest signal detectable by a receiver system that can be processed and presented on an indicator.

NEETS MODULE 18-Radar Principles

The frequency of the rf energy in the pulse radiated by a radar is referred to as the **CARRIER FREQUENCY** of the radar system. The carrier frequency is often a limiting factor in the maximum range capability of a radar system because radio frequency energy above 3,000 megahertz is rapidly attenuated by the atmosphere. This decreases the usable range of radio-frequency energy. Therefore, as the carrier frequency is increased, the transmitted power must also be increased to cover the same range. Long-range coverage is more easily achieved at lower frequencies because atmospheric conditions have less effect on low-frequency energy.

Radar systems radiate each pulse at the carrier frequency during transmit time, wait for returning echoes during listening or rest time, and then radiate a second pulse, as shown in figure 1-3. The number of pulses radiated in one second is called the pulse-repetition frequency (prf), or the pulse-repetition rate (prr). The time between the beginning of one pulse and the start of the next pulse is called **PULSEREPETITION TIME** (prt) and is equal to the reciprocal of prf as follows:

$$\text{prt} = \frac{1}{\text{prf}}$$

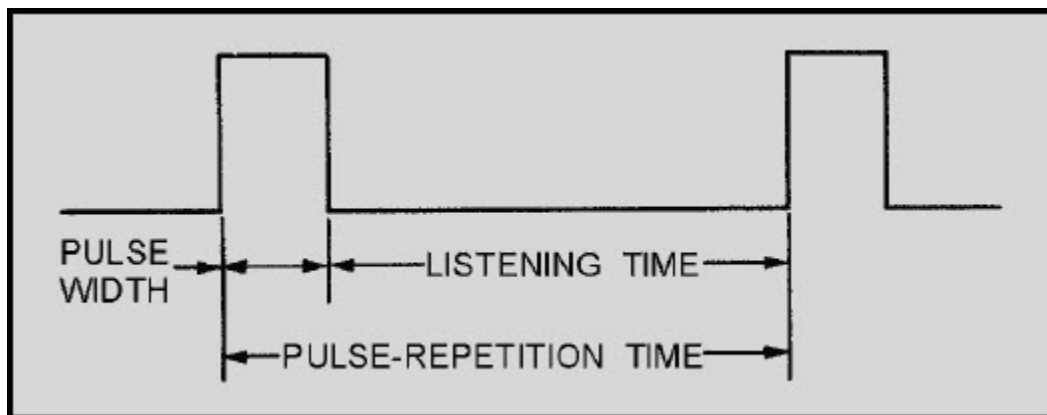

Figure 1-3 Radar pulse relationships

AMBIGUOUS RETURNS.—The radar timing system must be reset to zero each time a pulse is radiated. This is to ensure that the range detected is measured from time zero each time. The prt of the radar becomes important in maximum range determination because target return times that exceed the prt of the radar system appear at incorrect locations (ranges) on the radar screen. Returns that appear at these incorrect ranges are referred to as **AMBIGUOUS RETURNS** or **SECOND-SWEEP ECHOES**.

NEETS MODULE 18-Radar Principles

Figure 1-4 illustrates a radar system with a 1 millisecond prt. The pulses are shown at the top, and examples of two transmitted pulses hitting targets and returning are shown at the bottom. In the case of target A, the pulse travels round trip in 0.5 millisecond, which equates to a target range of 82,000 yards. Since 0.5 millisecond is less than 1 millisecond, displaying a correct range is no problem. However, target B is 196,800 yards distant from the radar system. In this case, total pulse travel time is 1.2 milliseconds and exceeds the prt limitation of 1 millisecond for this radar. While the first transmitted pulse is traveling to and returning from target B, a second pulse is transmitted and the radar system is reset to 0 again. The first pulse from target B continues its journey back to the radar system, but arrives during the timing period for the second pulse. This results in an inaccurate reading. In this case, the first return pulse from target B arrives 0.2 millisecond into the second timing period. This results in a range of 32,800 yards instead of the actual 196,800 yards. You should see from this example that pulse returns in excess of the prt of the radar system result in ambiguous ranges while pulse returns within the prt limits result in normal (unambiguous) ranges. The maximum unambiguous range for a given radar system can be determined by the following formula:

$$R_{\max \text{ unambiguous}} = \frac{162,000 \text{ miles /second}}{2} \times \text{prt}$$

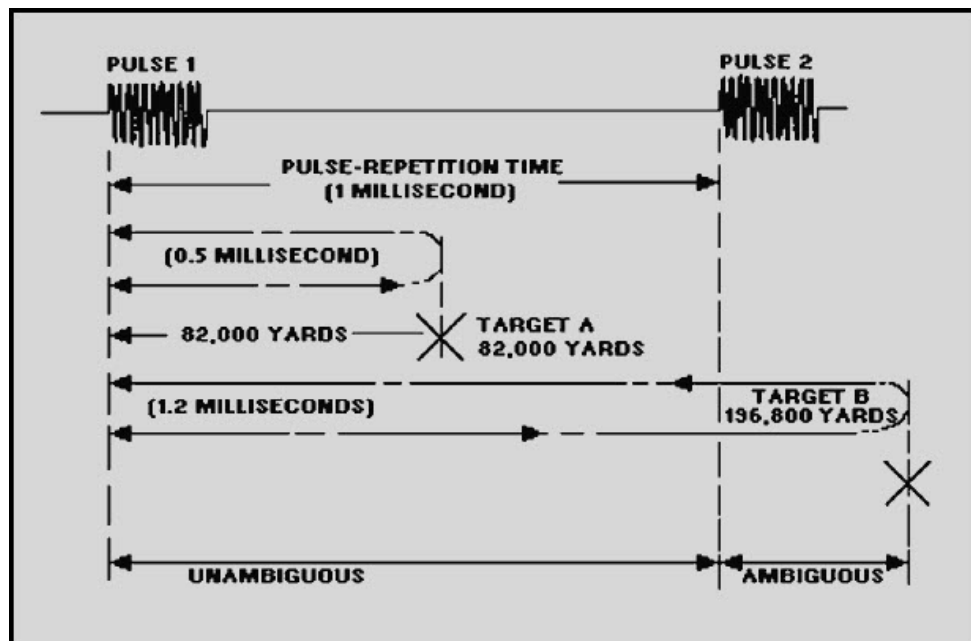

Figure 1-4 Maximum unambiguous range

NEETS MODULE 18-Radar Principles

Q3. What is the speed of electromagnetic energy traveling through air?

Q4. How much time is required for electromagnetic energy to travel 1 nautical mile and return to the source?

Q5. In addition to recovery time, what determines the minimum range of a radar set?

PULSE-REPETITION FREQUENCY AND POWER CALCULATIONS.—The energy content of a continuous-wave radar transmission may be easily figured because the transmitter operates continuously. However, pulsed radar transmitters are switched on and off to provide range timing information with each pulse. The resulting waveform for a transmitter was shown in figure 1-3. The amount of energy in this waveform is important because maximum range is directly related to transmitter output power. The more energy the radar system transmits, the greater the target detection range will be. The energy content of the pulse is equal to the PEAK (maximum) POWER LEVEL of the pulse multiplied by the pulse width. However, meters used to measure power in a radar system do so over a period of time that is longer than the pulse width. For this reason, pulse-repetition time is included in the power calculations for transmitters. Power measured over such a period of time is referred to as AVERAGE POWER. Figure 1-5 illustrates the way this average power would be shown as the *total* energy content of the pulse. The shaded area represents the total energy content of the pulse; the crosshatched area represents average power and is equal to peak power spread out over the prt. (Keep in mind, as you look at figure 1-5, that *no energy is actually present between pulses* in a pulsed radar system. The figure is drawn just to show you how average power is calculated.) Pulse-repetition time is used to help figure average power because it defines the total time from the beginning of one pulse to the beginning of the next pulse. Average power is figured as follows:

Where: P_{avg} = average power
 P_{pk} = peak power
 pw = pulse width
 prt = pulse-repetition time

$$P_{avg} = P_{pk} \times \frac{pw}{prt}$$

NEETS MODULE 18-Radar Principles

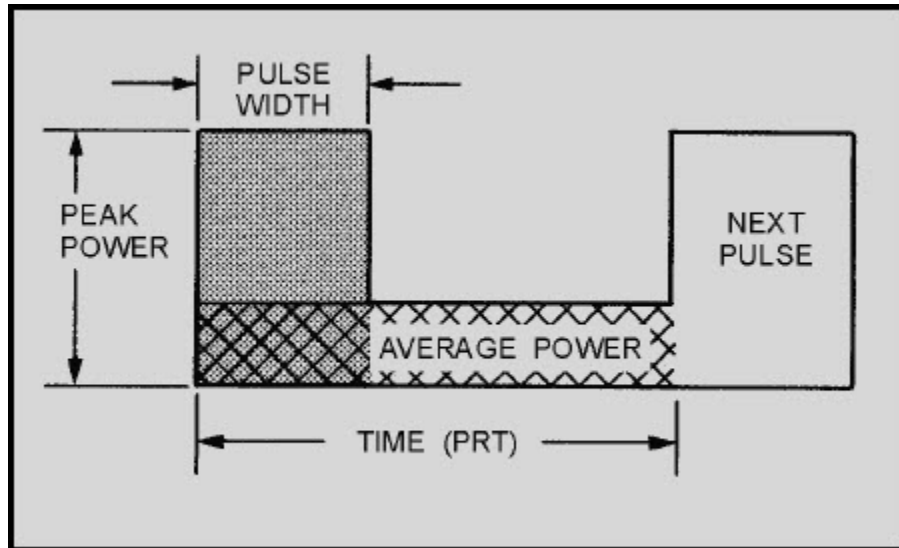

Figure 1-5 Pulse energy content

Because $1/\text{prt}$ is equal to prf , the formula may be written as follows:

$$P_{\text{avg}} = P_{\text{pk}} \times \text{pw} \times \text{prf}$$

The product of pulse width (pw) and pulse-repetition frequency (prf) in the above formula is called the **DUTY CYCLE** of a radar system. The duty cycle is a ratio of the *time on* to the *time off* of the transmitter, as shown in figure 1-6. The duty cycle is used to calculate both the peak power and average power of a radar system. The formula for duty cycle is shown below:

$$\text{duty cycle} = \text{pw} \times \text{prf}$$

NOTE: Pulse repetition frequency (prf) and pulse repetition rate (pr) are interchangeable terms.

NEETS MODULE 18-Radar Principles

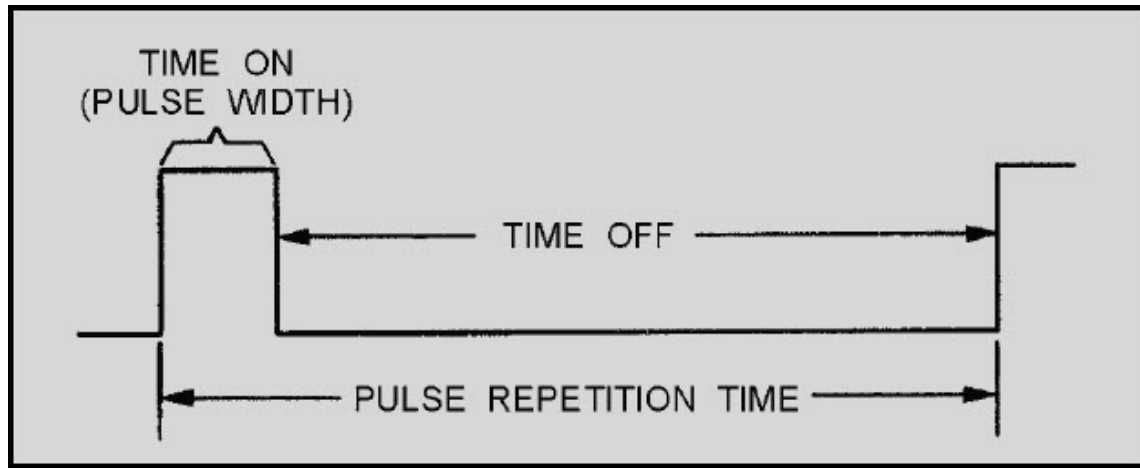

Figure 1-6 Duty cycle

Since the duty cycle of a radar is usually known, the most common formula for average power is expressed as:

$$P_{avg} = P_{pk} \times \text{duty cycle}$$

Transposing the above formula gives us a common formula for peak power:

$$P_{pk} = \frac{P_{avg}}{\text{duty cycle}}$$

Peak power must be calculated more often than average power. This is because, as previously mentioned, most measurement instruments measure average power directly. An example is shown below:

$$P_{avg} = 20,000 \text{ watts}$$

$$pw = 20 \text{ microseconds } (20 \times 10^{-6})$$

$$prf = 1,000 \text{ or } 10^3 \text{ pulses per second}$$

NEETS MODULE 18-Radar Principles

Before figuring P_p , you must figure duty cycle as follows:

$$\begin{aligned} \text{duty cycle} &= \text{pw} \times \text{prf} \\ &= 20 \times 10^{-6} \times 10^3 \quad 20 \times 10^{-3} \\ &= .02 \end{aligned}$$

Now that you have duty cycle, P_p may be calculated as follows:

$$\begin{aligned} P_{pk} &= \frac{P_{avg}}{\text{duty cycle}} \\ &= \frac{20,000}{.02} \\ &= 1,000,000 \text{ or } 10^6 \text{ watts} \end{aligned}$$

ANTENNA HEIGHT AND SPEED.—Another factor affecting radar range is antenna height. The high-frequency energy transmitted by a radar system travels in a straight line and does not normally bend to conform to the curvature of the earth. Because of this, the height of both the antenna and the target are factors in detection range. The distance to the horizon (in nautical miles) for a radar system varies with the height of the antenna according to the following formula:

$$\text{radar horizon distance} = 1.25\sqrt{\text{antenna height in feet}} \\ \text{(in nautical miles)}$$

NEETS MODULE 18-Radar Principles

For example, assume antenna height to be 64 feet in the following calculations:

$$\text{range} = \frac{\text{elapsed time}}{12.36 \text{ microseconds per nautical mile}}$$

A target at a range greater than the radar horizon will not be detected unless it is high enough to be above the horizon. An example of the antenna- and target-height relationship is shown in figure 1-7.

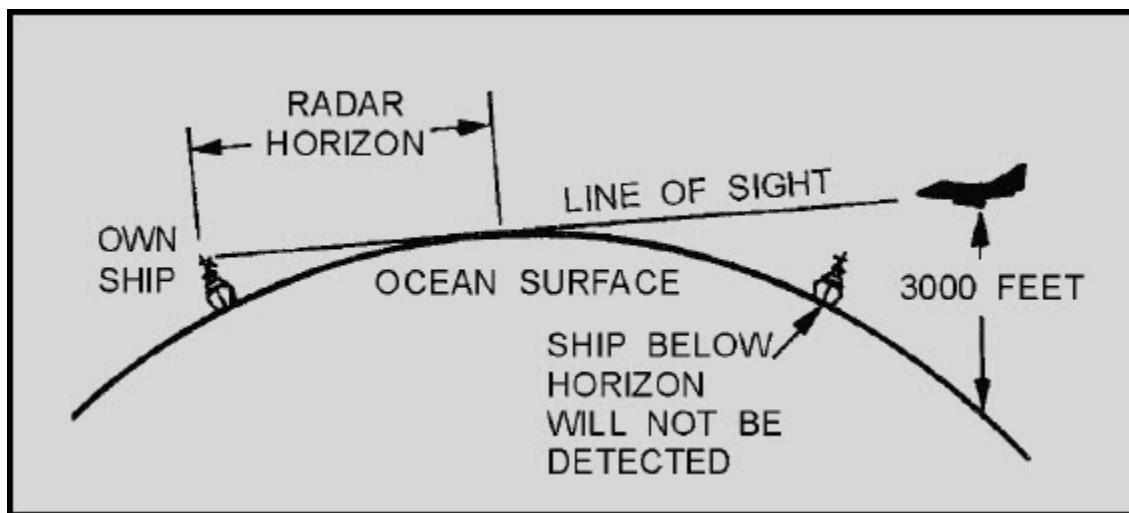

Figure 1-7 Radar horizon

The antenna-rotation rate also affects maximum detection range. The slower an antenna rotates, the greater the detection range of a radar system. When the antenna is rotated at 10 revolutions per minute (rpm), the beam of energy strikes each target for just one-half the time it would if the rotation were 5 rpm.

The number of strikes per antenna revolution is referred to as HITS PER SCAN. During each revolution enough pulses must be transmitted to return a usable echo.

NOTE: The more pulses transmitted to a given area (at slower antenna speeds), the greater the number of hits per scan.

NEETS MODULE 18-Radar Principles

As an example, if the antenna rotates at 20 rpm, it completes a revolution in 3 seconds. During this time, a transmitter with a prf of 200 pulses per second (pps) transmits 600 pulses. Since 360 degrees of azimuth must be covered, the following formula shows the number of pulses for each degree of azimuth:

$$\frac{600 \text{ pulses per revolution}}{360 \text{ degrees per revolution}} = 1.67 \text{ pulses per degree}$$

Such a low number of pulses for any given target area greatly increases the likelihood that some targets will be missed entirely; therefore, prf and antenna speed must be matched for maximum efficiency.

Q6. Atmospheric interference with the travel of electromagnetic energy increases with what rf energy characteristic?

Q7. How is prt related to prf?

Q8. What type of radar transmitter power is measured over a period of time?

Q9. What term is used to describe the product of pulse width and pulse-repetition frequency?

NEETS MODULE 18-Radar Principles

1.2.2 Bearing

The **TRUE BEARING** (referenced to true north) of a radar target is the angle between true north and a line pointed directly at the target. This angle is measured in the horizontal plane and in a clockwise direction from true north. The bearing angle to the radar target may also be measured in a clockwise direction from the centerline of your own ship or aircraft and is referred to as the **RELATIVE BEARING**. Both true and relative bearing angles are illustrated in figure 1-8.

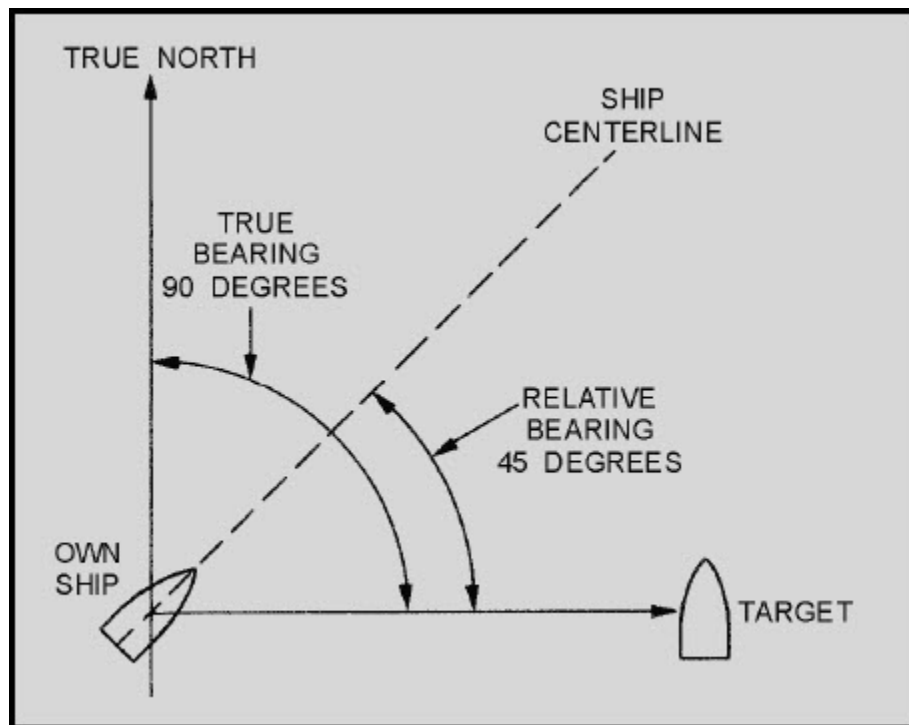

Figure 1-8 True and relative bearings

The antennas of most radar systems are designed to radiate energy in a one-directional lobe or beam that can be moved in bearing simply by moving the antenna. As you can see in figure 1-9, the shape of the beam is such that the echo signal strength varies in amplitude as the antenna beam moves across the target. At antenna position **A**, the echo is minimal; at position **B**, where the beam axis is pointing directly at the target, the echo strength is maximum. Thus, the bearing angle of the target can be obtained by moving the antenna to the position at which the echo is strongest. In actual practice, search radar antennas move continuously; the point of maximum echo return is determined by the detection circuitry as the beam passes the target or visually by the operator. Weapons-control and guidance radar systems are positioned to the point of maximum signal return and maintained at that position either manually or by automatic tracking circuits.

NEETS MODULE 18-Radar Principles

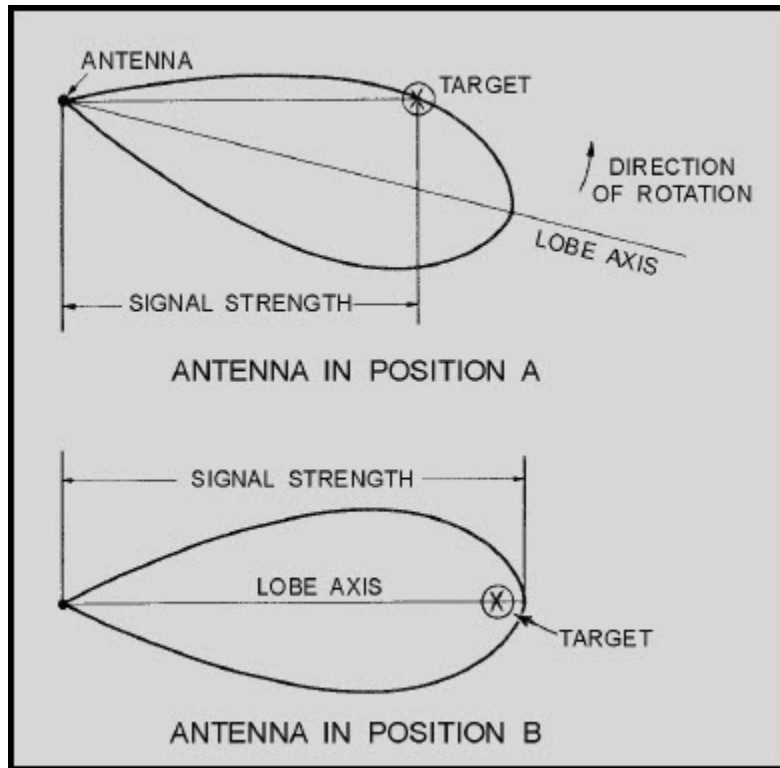

Figure 1-9 Determination of bearing

1.2.3 Altitude

Many radar systems are designed to determine only the range and bearing of an object. Such radar systems are called TWO-DIMENSIONAL (2D) radars. In most cases these systems are further described as SEARCH RADAR SYSTEMS and function as early-warning devices that search a fixed volume of space. The range and bearing coordinates provide enough information to place the target in a general area with respect to the radar site and to determine distance, direction of travel, and relative speed. However, when action must be taken against an airborne target, altitude must be known as well. A search radar system that detects altitude as well as range and bearing is called a THREE-DIMENSIONAL (3D) radar.

NEETS MODULE 18-Radar Principles

Altitude- or height-finding search radars use a beam that is very narrow in the vertical plane. The beam is scanned in elevation, either mechanically or electronically, to pinpoint targets. Height-finding radar systems that also determine bearing must have a beam that is very narrow in both the vertical and horizontal planes. An electronic elevation-scanning pattern for a search radar set is illustrated in figure 1-10. Lines originating at the antenna indicate the number of beam positions required for complete elevation coverage. In practice the beams overlap slightly to prevent any gaps in the coverage. Each beam position corresponds to a slight change in either the frequency or phase of the radiated energy. A change in either phase or frequency of the energy causes it to leave the antenna at a different angle. Thus, the frequency or phase can be predetermined to create an orderly scanning pattern that covers the entire vertical plane. Electronic scanning permits automatic compensation for an unstable radar platform (site), such as a ship at sea. Error signals are produced by the roll and pitch of the ship and are used to correct the radar beam to ensure complete elevation coverage.

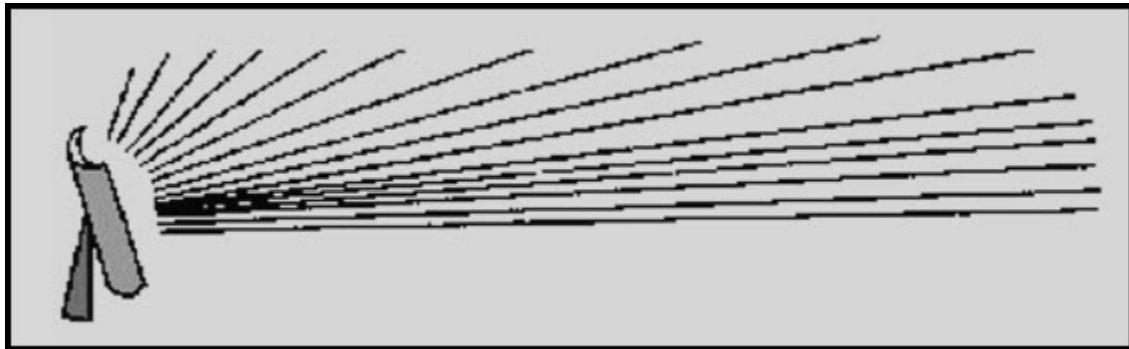

Figure 1-10 Electronic elevation scan

Mechanical elevation scanning is achieved by mechanically moving the antenna or radiation source. Weapons-control and tracking radar systems commonly use mechanical elevation scanning techniques. Most electronically scanned radar systems are used as air search radars. Some older air-search radar systems use a mechanical elevation scanning device; however, these are being replaced by electronically scanned radar systems.

NEETS MODULE 18-Radar Principles

Q10. What type of target bearing is referenced to your ship?

Q11. What type of radar detects range, bearing, and height?

Q12. What characteristic(s) of radiated energy is (are) altered to achieve electronic scanning?

1.2.4 Target Resolution

The TARGET RESOLUTION of a radar is its ability to distinguish between targets that are very close together in either range or bearing. Weapons-control radar, which requires great precision, should be able to distinguish between targets that are only yards apart. Search radar is usually less precise and only distinguishes between targets that are hundreds of yards or even miles apart. Resolution is usually divided into two categories; RANGE RESOLUTION and BEARING RESOLUTION.

1.2.4.1 Range Resolution

Range resolution is the ability of a radar system to distinguish between two or more targets on the same bearing but at different ranges. The degree of range resolution depends on the width of the transmitted pulse, the types and sizes of targets, and the efficiency of the receiver and indicator. Pulse width is the primary factor in range resolution. A well-designed radar system, with all other factors at maximum efficiency, should be able to distinguish targets separated by one-half the pulse width time. Therefore, the theoretical range resolution of a radar system can be calculated from the following formula:

$$\text{range resolution} = \frac{\text{pw (microseconds)}}{2} \times 328 \text{ yards per microsecond}$$

(in yards)

NEETS MODULE 18-Radar Principles

The above formula is often written as:

$$\text{range resolution} = \text{pw} \times 164 \text{ yards per microsecond}$$

For example, if a radar system has a pulse width of 5 microseconds, the range resolution is calculated as follows:

$$\begin{aligned} \text{range resolution} &= \text{pw} \times 164 \text{ yards per microsecond} \\ &= 5 \times 164 \text{ yards per microsecond} \\ &= 820 \text{ yards} \end{aligned}$$

In the above example, targets on the same bearing would have to be separated by more than 820 yards to show up as two targets on your indicator.

1.2.4.2 Bearing Resolution

Bearing, or azimuth, resolution is the ability of a radar system to separate objects at the same range but at different bearings. The degree of bearing resolution depends on radar beam width and the range of the targets. Range is a factor in bearing resolution because the radar beam spreads out as range increases. A RADAR BEAM is defined in width in terms of HALF-POWER POINTS. All the points off the centerline of the beam that are at one-half the power level at the center are plotted to define beam width. When the half-power points are connected to the antenna by a curve, such as that shown in figure 1-11, the resulting angular width of the curve is called the ANTENNA BEAM WIDTH. The physical size and shape of the antenna determines beam width. Beam width can vary from about 1 degree up to 60 degrees. In figure 1-11, only the target within the half-power points will reflect a useful echo. Two targets at the same range must be separated by at least one beam width to be distinguished as two objects.

NEETS MODULE 18-Radar Principles

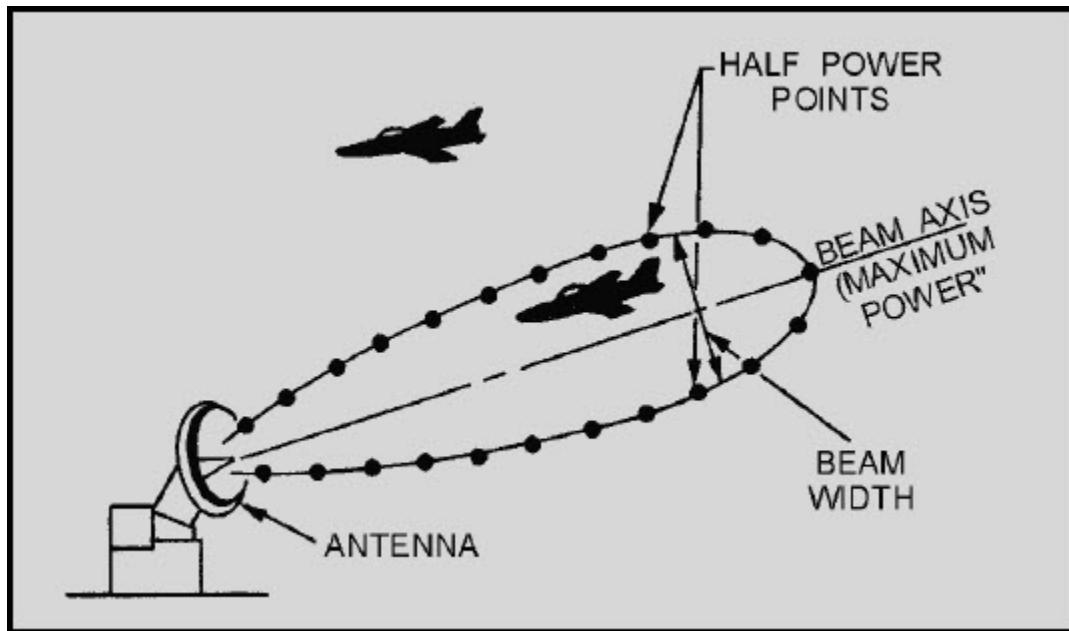

Figure 1-11 Beam half-power points

1.2.5 Radar Accuracy

Radar accuracy is a measure of the ability of a radar system to determine the correct range, bearing, and, in some cases, height of an object. The degree of accuracy is primarily determined by the resolution of the radar system. Some additional factors affecting accuracy are pulse shape and atmospheric conditions.

1.2.5.1 Pulse Shape

In the case of a pulse radar, the shape and width of the rf pulse influences minimum range, range accuracy, and maximum range. The ideal pulse shape is a square wave having vertical leading and trailing edges. However, equipments do not usually produce the ideal waveforms.

The factors influencing minimum range are discussed first. Since the receiver cannot receive target reflections while the transmitter is operating, you should be able to see that a narrow pulse is necessary for short ranges. A sloping trailing edge extends the width of the transmitter pulse, although it may add very little to the total power generated. Therefore, along with a narrow pulse, the trailing edge should be as near vertical as possible.

NEETS MODULE 18-Radar Principles

A sloping leading edge also affects minimum range as well as range accuracy since it provides no definite point from which to measure elapsed time on the indicator time base. Using a starting point at the lower edge of the pulse's leading edge would increase minimum range. Using a starting point high up on the slope would reduce the accuracy of range measurements at short ranges which are so vital for accurate solution of the fire-control problem.

Maximum range is influenced by pulse width and pulse repetition frequency (prf). Since a target can reflect only a very small part of the transmitted power, the greater the transmitted power, the greater the strength of the echo that could be received. Thus, a transmitted pulse should quickly rise to its maximum amplitude, remain at this amplitude for the duration of the desired pulse width, and decay instantaneously to zero. Figure 1-12 illustrates the effects of pulse shapes.

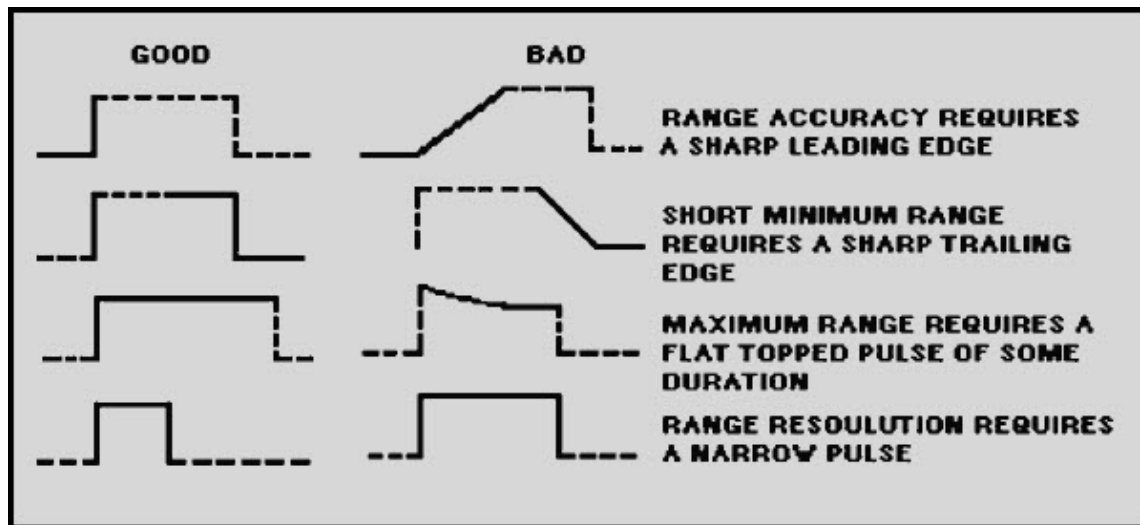

Figure 1-12 Pulse shapes and effects

1.2.5.2 Atmospheric Conditions

Electromagnetic wavefronts travel through empty space in straight lines at the speed of light, but the REFRACTIVE INDEX of the atmosphere affects both the travel path and the speed of the electromagnetic wavefront. The path followed by electromagnetic energy in the atmosphere, whether direct or reflected, usually is slightly curved; and the speed is affected by temperature, atmospheric pressure, and the amount of water vapor present in the atmosphere, which all affect the refractive index. As altitude increases, the combined effects of these influences, under normal atmospheric conditions, cause a small, uniform increase in signal speed. This increase in speed causes the travel path to curve slightly downward, as shown in figure 1-13. The downward curve extends the radar horizon beyond a line tangent to the earth, as illustrated in figure 1-14.

NEETS MODULE 18-Radar Principles

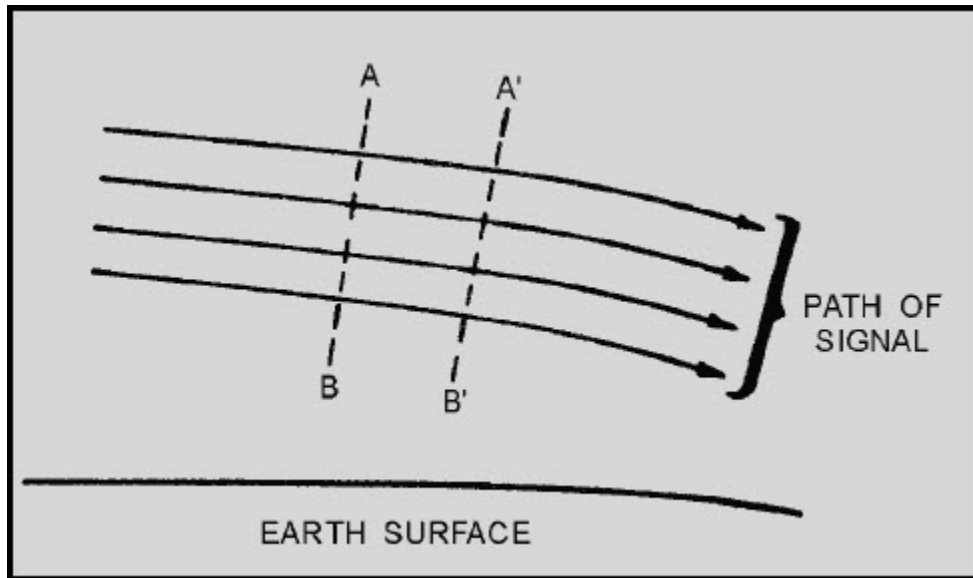

Figure 1-13 Wavefront path

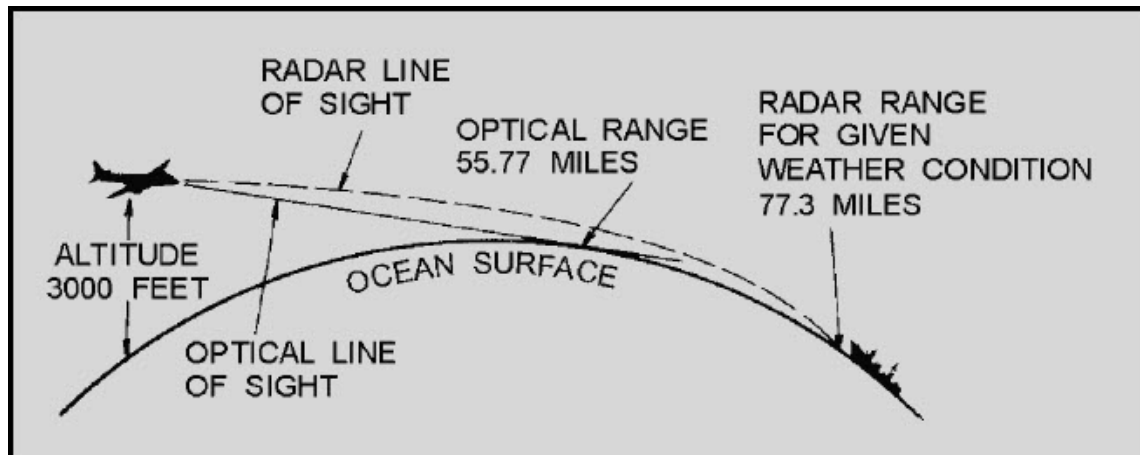

Figure 1-14 Extension of the radar horizon

The reason for the downward curve can be illustrated using line **AB** in figure 1-13. Line **AB** represents the surface of a wavefront with point A higher in altitude than point B. As wavefront **AB** moves to the point represented by **A'B'**, the speed at A and A' is faster than the speed at B and B' since A and A' are at a greater altitude. Therefore, in a given time, the upper part of the wavefront moves farther than the lower part. The wavefront leans slightly forward as it moves. Since the direction of energy propagation is always perpendicular to the surface of a wavefront, the tilted wavefront causes the energy path to curve downward.

NEETS MODULE 18-Radar Principles

REFRACTION is the bending of electromagnetic waves caused by a change in the density of the medium through which the waves are passing. A visible example of electromagnetic refraction is the apparent displacement of underwater objects caused by the bending of light as it passes from the atmosphere into the water. An INDEX OF REFRACTION has been established which indicates the degree of refraction, or bending, caused by different substances. Because the density of the atmosphere changes with altitude, the index of refraction changes gradually with height.

The temperature and moisture content of the atmosphere normally decrease uniformly with an increase in altitude. However, under certain conditions the temperature may first increase with height and then begin to decrease. Such a situation is called a temperature inversion. An even more important deviation from normal may exist over the ocean. Since the atmosphere close to the surface over large bodies of water may contain more than a normal amount of moisture, the moisture content may decrease more rapidly at heights just above the sea. This effect is referred to as MOISTURE LAPSE.

Either temperature inversion or moisture lapse, alone or in combination, can cause a large change in the refraction index of the lowest few-hundred feet of the atmosphere. The result is a greater bending of the radar waves passing through the abnormal condition. The increased bending in such a situation is referred to as DUCTING and may greatly affect radar performance. The radar horizon may be extended or reduced, depending on the direction the radar waves are bent. The effect of ducting on radar waves is illustrated in figure 1-15.

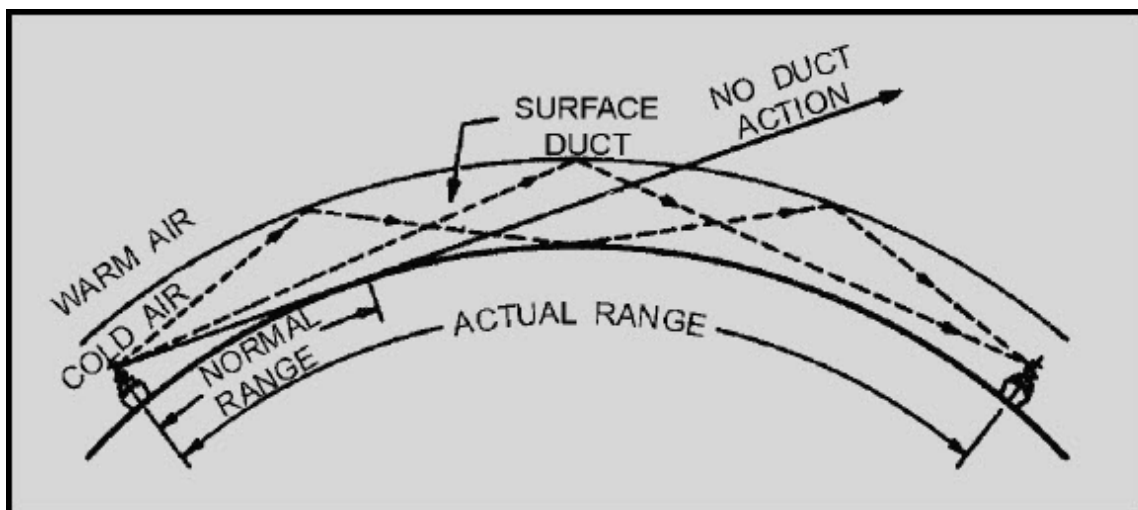

Figure 1-15 Ducting effect on the radar wave

NEETS MODULE 18-Radar Principles

Another effect of the atmosphere on radar performance is caused by particles suspended in the air. Water droplets and dust particles diffuse radar energy through absorption, reflection, and scattering so less energy strikes the target. Consequently, the return echo is smaller. The overall effect is a reduction in usable range that varies widely with weather conditions. The higher the frequency of a radar system, the more it is affected by weather conditions such as rain or clouds. In some parts of the world, dust suspended in the air can greatly decrease the normal range of high-frequency radar.

Q13. What term is used to describe the ability of a radar system to distinguish between targets that are close together?

Q14. The degree of bearing resolution for a given radar system depends on what two factors?

Q15. What happens to the speed of electromagnetic energy traveling through air as the altitude increases?

Q16. What term is used to describe a situation in which atmospheric temperature first increases with altitude and then begins to decrease?

1.3 RADAR PRINCIPLES OF OPERATION

Radar systems, like other complex electronics systems, are composed of several major subsystems and many individual circuits. This section will introduce you to the major subsystems common to most radar sets. A brief functional description of subsystem principles of operation will be provided. A much more detailed explanation of radar subsystems will be given in chapters 2 and 3. Since most radar systems in use today are some variation of the pulse radar system, the units discussed in this section will be those used in pulse radar. All other types of radar use some variation of these units, and these variations will be explained as necessary.

NEETS MODULE 18-Radar Principles

1.3.1 RADAR COMPONENTS

Pulse radar systems can be functionally divided into the six essential components shown in figure 1-16. These components are briefly described in the following paragraphs and will be explained in detail after that:

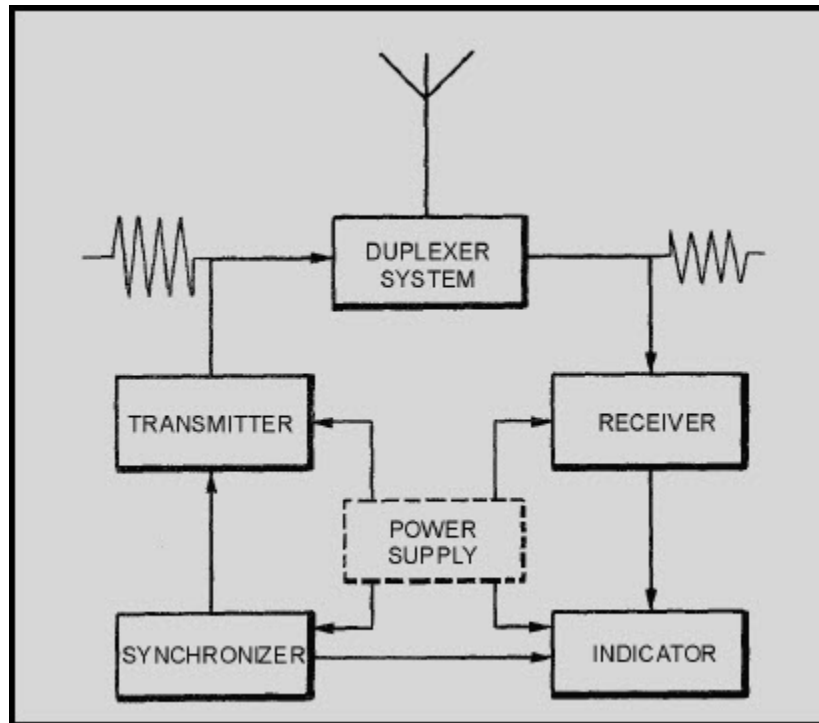

Figure 1-16 Functional block diagram of a basic radar system

- The SYNCHRONIZER (also referred to as the TIMER or KEYSER) supplies the synchronizing signals that time the transmitted pulses, the indicator, and other associated circuits.
- The TRANSMITTER generates electromagnetic energy in the form of short, powerful pulses.
- The DUPLEXER allows the same antenna to be used for transmitting and receiving.
- The ANTENNA SYSTEM routes the electromagnetic energy from the transmitter, radiates it in a highly directional beam, receives any returning echoes, and routes those echoes to the receiver.
- The RECEIVER amplifies the weak, electromagnetic pulses returned from the reflecting object and reproduces them as video pulses that are sent to the indicator.

NEETS MODULE 18-Radar Principles

- The INDICATOR produces a visual indication of the echo pulses in a manner that, at a minimum, furnishes range and bearing information.

While the physical configurations of radar systems differ, any radar system can be represented by the functional block diagram in figure 1-16. An actual radar set may have several of these functional components within one physical unit, or a single one of these functions may require several physical units. However, the functional block diagram of a basic radar set may be used to analyze the operation of almost any radar set.

In the following paragraphs, a brief description of the operation of each of the major components is given.

1.3.1.1 Synchronizer (Timer)

The synchronizer ensures that all circuits connected with the radar system operate in a definite timed relationship. It also times the interval between transmitted pulses to ensure that the interval is of the proper length. Timing pulses are used to ensure synchronous circuit operation and are related to the prf. The prf can be set by any stable oscillator, such as a sine-wave oscillator, multivibrator, or a blocking oscillator. That output is then applied to pulse-shaping circuits to produce timing pulses. Associated components can be timed by the output of the synchronizer or by a timing signal from the transmitter as it is turned on.

1.3.1.2 Transmitter

The transmitter generates powerful pulses of electromagnetic energy at precise intervals. The required power is obtained by using a high-power microwave oscillator, such as a magnetron, or a microwave amplifier, such as a klystron, that is supplied by a low-power rf source. (The construction and operation of microwave components can be reviewed in NEETS, Module 11, *Microwave Principles*.) The high-power generator, whether an oscillator or amplifier, requires operating power in the form of a properly-timed, high-amplitude, rectangular pulse. This pulse is supplied by a transmitter unit called the MODULATOR. When a high-power oscillator is used, the modulator high-voltage pulse switches the oscillator on and off to supply high-power electromagnetic energy. When a microwave power amplifier is used, the modulator pulse activates the amplifier just before the arrival of an electromagnetic pulse from a preceding stage or a frequency-generation source. Normally, because of the extremely high voltage involved, the modulator pulse is supplied to the cathode of the power tube and the plate is at ground potential to shield personnel from shock hazards. The modulator pulse may be more than 100,000 volts in high-power radar transmitters. In any case, radar transmitters produce voltages, currents, and radiation hazards that are extremely dangerous to personnel. Safety precautions must always be strictly observed when working in or around a radar transmitter.

NEETS MODULE 18-Radar Principles

1.3.1.3 Duplexer

A duplexer is essentially an electronic switch that permits a radar system to use a single antenna to both transmit and receive. The duplexer must connect the antenna to the transmitter and disconnect the antenna from the receiver for the duration of the transmitted pulse. The receiver must be completely isolated from the transmitted pulse to avoid damage to the extremely sensitive receiver input circuitry. After the transmitter pulse has ended, the duplexer must rapidly disconnect the transmitter and connect the receiver to the antenna. As previously mentioned, the switching time is called receiver recovery time, and must be very fast if close-in targets are to be detected. Additionally, the duplexer should absorb very little power during either phase of operation. Low-loss characteristics are particularly important during the receive period of duplexer operation. This is because the received signals are of extremely low amplitude.

1.3.1.4 Antenna System

The antenna system routes the pulse from the transmitter, radiates it in a directional beam, picks up the returning echo, and passes it to the receiver with a minimum of loss. The antenna system includes the antenna, transmission lines and waveguide from the transmitter to the antenna, and the transmission line and waveguide from the antenna to the receiver. In some publications the duplexer is included as a component of the antenna system.

1.3.1.5 Receiver

The receiver accepts the weak echo signals from the antenna system, amplifies them, detects the pulse envelope, amplifies the pulses, and then routes them to the indicator. One of the primary functions of the radar receiver is to convert the frequency of the received echo signal to a lower frequency that is easier to amplify. This is because radar frequencies are very high and difficult to amplify. This lower frequency is called the INTERMEDIATE FREQUENCY (IF). The type of receiver that uses this frequency conversion technique is the SUPER HETERODYNE RECEIVER. Superheterodyne receivers used in radar systems must have good stability and extreme sensitivity. Stability is ensured by careful design and the overall sensitivity is greatly increased by the use of many IF stages.

NEETS MODULE 18-Radar Principles

1.3.1.6 Indicator

The indicator uses the received signals routed from the radar receiver to produce a visual indication of target information. The cathode-ray oscilloscope is an ideal instrument for the presentation of radar data. This is because it not only shows a variation of a single quantity, such as voltage, but also gives an indication of the relative values of two or more quantities. The sweep frequency of the radar indicator is determined by the pulse-repetition frequency of the radar system. Sweep duration is determined by the setting of the range-selector switch. Since the indicator is so similar to an oscilloscope, the term RADAR SCOPE is commonly used when referring to radar indicators.

Q17. What radar subsystem supplies timing signals to coordinate the operation of the complete system?

Q18. When a transmitter uses a high-power oscillator to produce the output pulse, what switches the oscillator on and off?

Q19. What radar component permits the use of a single antenna for both transmitting and receiving?

1.3.2 Scanning

Radar systems are often identified by the type of SCANNING the system uses. Scanning is the systematic movement of a radar beam in a definite pattern while searching for or tracking a target. The type and method of scanning used depends on the purpose and type of radar and on the antenna size and design. In some cases, the type of scan will change with the particular system mode of operation. For example, in a particular radar system, the search mode scan may be quite different from that of the track mode scan.

NEETS MODULE 18-Radar Principles

1.3.2.1 Stationary-Lobe Scanning

A SINGLE STATIONARY-LOBE SCANNING SYSTEM is the simplest type of scanning. This method produces a single beam that is stationary in relation to the antenna. The antenna is then mechanically rotated continuously to obtain complete 360-degree azimuth coverage. A stationary lobe, however, cannot satisfactorily track a moving object because it does not provide enough information about the object's movement to operate automatic tracking circuits, such as those in fire-control tracking radar. A two-dimensional search radar, however, does use a single-lobe that is scanned in a 360-degree pattern because automatic tracking circuits are not normally used in 2D radars.

Single-lobe scanning is unsuitable for use as a tracking radar for several reasons. For example, let's assume that a target is somewhere on the lobe axis and the receiver is detecting signals reflected from the target. If these reflected signals begin to decrease in strength, the target likely has flown off the lobe axis. In this case, the beam must be moved to continue tracking. The beam might be moved by an operator tracking the target with an optical sight, but such tracking is slow, inaccurate, and limited by conditions of visibility. An automatic tracking system would require that the beam SCAN, or search, the target area in such a case.

Again, assume that a missile is riding (following) the axis of a single beam. The strength of the signals it receives (by means of a radar receiver in the missile) will gradually decrease as its distance from the transmitter increases. If the signal strength decreases suddenly, the missile will know, from built-in detection circuitry, that it is no longer on the axis of the lobe. But it will *not* know which way to turn to get back on the axis. A simple beam does not contain enough information for missile guidance.

1.3.2.2 Methods of Beam Scanning

The two basic methods of beam scanning are MECHANICAL and ELECTRONIC. In mechanical scanning, the beam can be moved in various ways: (1) The entire antenna can be moved in the desired pattern; (2) the energy feed source can be moved relative to a fixed reflector; or (3) the reflector can be moved relative to a fixed source. In electronic scanning, the beam is effectively moved by such means as (1) switching between a set of feeder sources, (2) varying the phasing between elements in a multielement array, or (3) comparing the amplitude and phase differences between signals received by a multielement array. A combination of mechanical and electronic scanning is also used in some antenna systems.

NEETS MODULE 18-Radar Principles

MECHANICAL SCANNING.—The most common type of mechanical scanning is the rotation of the antenna through 360 degrees to obtain azimuth coverage. Most search radar sets use this method. A common form of scanning for target tracking or missile beam-rider systems is CONICAL (cone-like) SCANNING. This is generally accomplished mechanically by NUTATING the rf feed point.

Nutation is difficult to describe in words but easy to demonstrate. Hold a pencil in two hands. While holding the eraser end as still as possible, swing the point in a circular motion. This motion of the pencil is referred to as nutation; the pencil point corresponds to the open, or transmitting, end of the waveguide antenna. The important fact to remember is that polarization of the beam is not changed during the scanning cycle. This means that the axis of the moving feeder does not change either horizontal or vertical orientation while the feeder is moving. You might compare the feeder movement to that of a ferris wheel; that is, the vertical orientation of each seat remains the same regardless of the position of the wheel.

Recall that a waveguide is a metal pipe, usually rectangular in cross section, used to conduct the rf energy from the transmitter to the antenna. The open end of the waveguide faces the concave side of the reflector and the rf energy it emits is bounced from the reflector surface.

A conical scan can be generated by nutation of the waveguide. In this process the axis of the waveguide itself is moved through a small conical pattern. In an actual installation of a nutating waveguide, the three-dimensional movement is fast and of small amplitude. To an observer, the waveguide appears merely to be vibrating slightly.

By movement of either the waveguide or the antenna, you can generate a conical scan pattern, as shown in figure 1-17. The axis of the radar lobe is made to sweep out a cone in space; the apex of this cone is, of course, at the radar transmitter antenna or reflector. At any given distance from the antenna, the path of the lobe axis is a circle. Within the useful range of the beam, the inner edge of the lobe always overlaps the axis of scan.

NEETS MODULE 18-Radar Principles

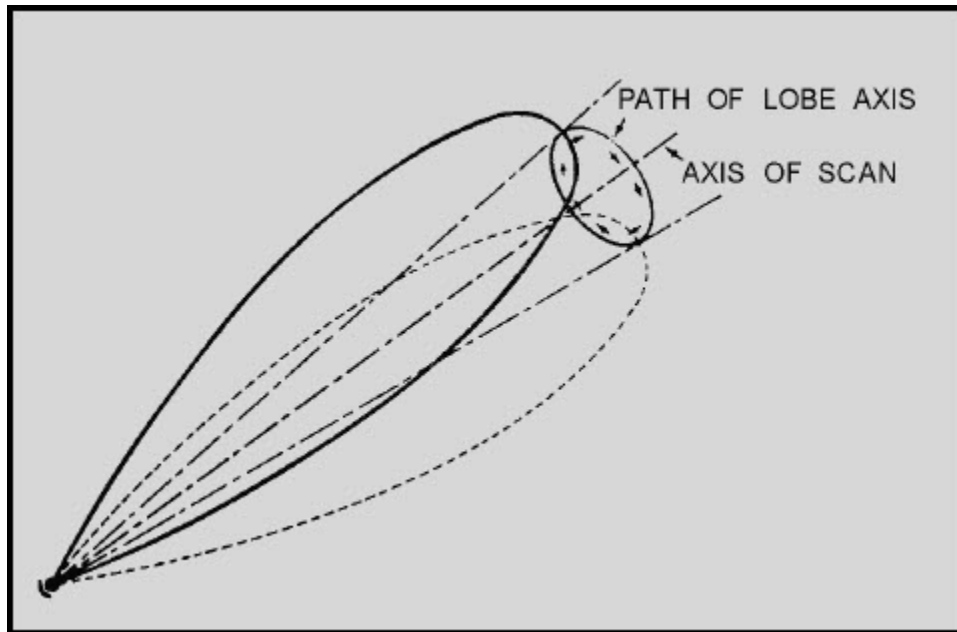

Figure 1-17 Conical scanning.

Now assume that we use a conically scanned beam for target tracking. If the target is on the scan axis, the strength of the reflected signals remains constant (or changes gradually as the range changes). But if the target is slightly off the axis, the amplitude of the reflected signals will change at the scan rate. For example, if the target is to the left of the scan axis, as shown in figure 1-18, the reflected signals will be of maximum strength as the lobe sweeps through the left part of its cone; the signals will quickly decrease to a minimum as the lobe sweeps through the right part. Information on the instantaneous position of the beam, relative to the scan axis, and on the strength of the reflected signals is fed to a computer. Such a computer in the radar system is referred to as the angle-tracking or angle-servo circuit (also angle-error detector). If the target moves off the scan axis, the computer instantly determines the direction and amount of antenna movement required to continue tracking. The computer output is used to control servomechanisms that move the antenna. In this way, the target is tracked accurately and automatically.

NEETS MODULE 18-Radar Principles

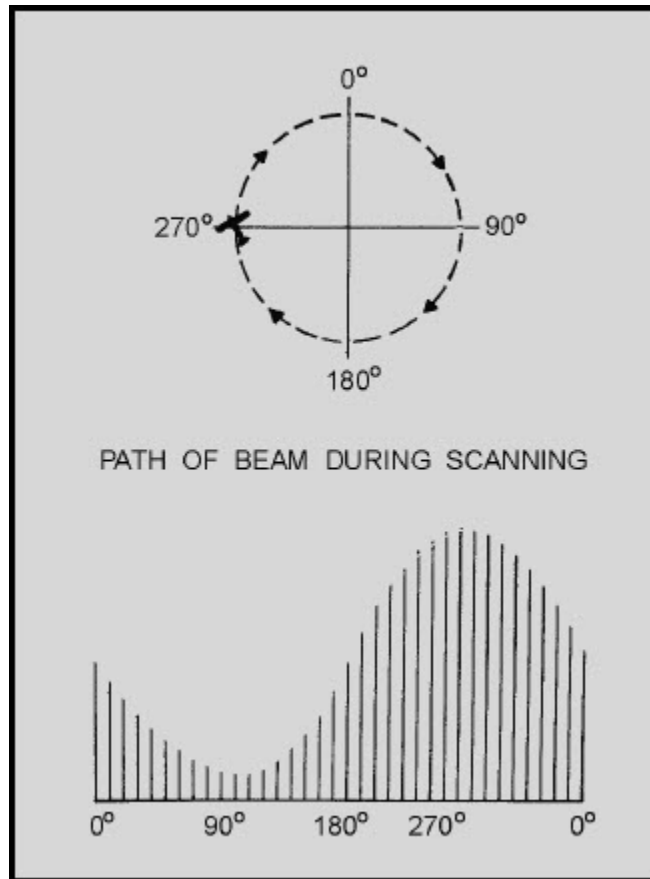

Figure 1-18 Reflected signal strength

Q20. What is the simplest type of scanning?

Q21. How does the operator of a single-lobe scanning system determine when the target moves off the lobe axis?

Q22. What are the two basic methods of scanning?

Q23. Rotation of an rf-feed source to produce a conical scan pattern is identified by what term?

NEETS MODULE 18-Radar Principles

ELECTRONIC SCANNING.—Electronic scanning can accomplish lobe motion more rapidly than, and without the inherent maintenance disadvantages of, the mechanical systems. Because electronic scanning cannot generally cover as large an area of space, it is sometimes combined with mechanical scanning in particular applications.

With **MONOPULSE (SIMULTANEOUS) LOBING**, all range, bearing, and elevation-angle information of a target is obtained from a single pulse. Monopulse scanning is used in fire-control tracking radars.

For target tracking, the radar discussed here produces a narrow circular beam of pulsed-rf energy at a high pulse-repetition rate. Each pulse is divided into four signals which are equal both in amplitude and phase. These four signals are radiated at the same time from each of four feedhorns that are grouped in a cluster. The resulting radiated energy is focused into a beam by a microwave lens. Energy reflected from targets is refocused by the lens back into the feedhorns. The total amount of the energy received by each horn varies, depending on the position of the target relative to the beam axis. This is illustrated in figure 1-19 for four targets at different positions with respect to the beam axis. Note that a phase inversion takes place at the microwave lens similar to the image inversion that takes place in an optical system.

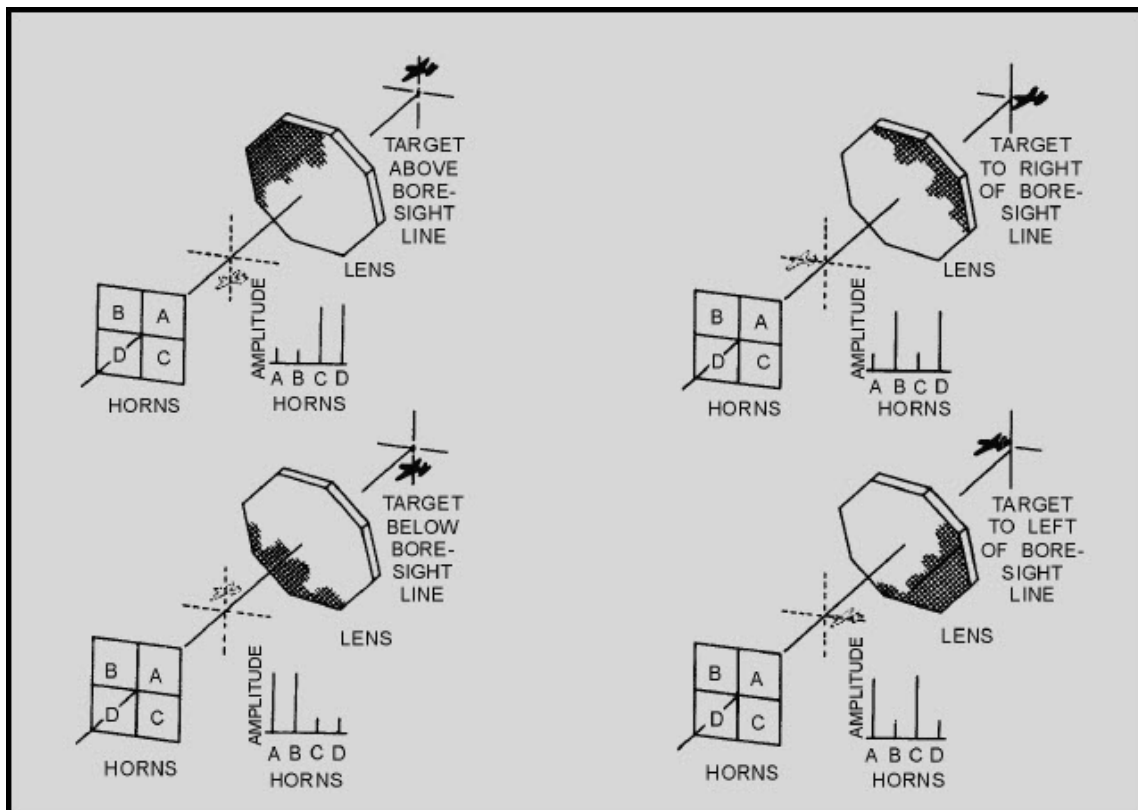

Figure 1-19 Monopulse scanning

NEETS MODULE 18-Radar Principles

The amplitude of returned signals received by each horn is continuously compared with those received in the other horns. Error signals are generated which indicate the relative position of the target with respect to the axis of the beam. Angle servo circuits receive these error signals and correct the position of the radar beam to keep the beam axis on target.

The TRAVERSE (BEARING) SIGNAL is made up of signals from horn **A** added to **C** and from horn **B** added to **D**. By waveguide design, the sum of **B** and **D** is made 180 degrees out of phase with the sum of **A** and **C**. These two are combined and the traverse signal is the difference of $(\mathbf{A} + \mathbf{C}) - (\mathbf{B} + \mathbf{D})$. Since the horns are positioned as shown in figure 1-19, the relative amplitudes of the horn signals give an indication of the magnitude of the traverse error. The elevation signal consists of the signals from horns **C** and **D** added 180 degrees out of phase with horns **A** and **B** $[(\mathbf{A} + \mathbf{B}) - (\mathbf{C} + \mathbf{D})]$. The sum, or range, signal is composed of signals from all four feedhorns added together in phase. It provides a reference from which target direction from the center of the beam axis is measured. The range signal is also used as a phase reference for the traverse and elevation-error signals.

The traverse and elevation error signals are compared in the radar receiver with the range or reference signal. The output of the receiver may be either positive or negative pulses; the amplitudes of the pulses are proportional to the angle between the beam axis and a line drawn to the target. The polarities of the output pulses indicate whether the target is above or below, to the right or to the left of the beam axis. Of course, if the target is directly on the line of sight, the output of the receiver is zero and no angle-tracking error is produced.

An important advantage of a monopulse-tracking radar over radar using conical scan is that the instantaneous angular measurements are not subject to errors caused by target SCINTILLATION. Scintillation can occur as the target maneuvers or moves and the radar pulses bounce off different areas of the target. This causes random reflectivity and may lead to tracking errors. Monopulse tracking radar is not subject to this type of error because each pulse provides an angular measurement without regard to the rest of the pulse train; no such cross-section fluctuations can affect the measurement. An additional advantage of monopulse tracking is that no mechanical action is required.

ELECTRONIC SCANNING used in search radar systems was explained in general terms earlier in this chapter during the discussion of elevation coverage. This type of electronic scanning is often called FREQUENCY SCANNING. An in-depth explanation of frequency scanning theory can be found in the fire control technician rate training manuals.

NEETS MODULE 18-Radar Principles

1.4 RADAR TRANSMISSION METHODS

Radar systems are normally divided into operational categories based on energy transmission methods. Up to this point, we have mentioned only the pulse method of transmission to illustrate basic radar concepts. Although the pulse method is the most common method of transmitting radar energy, two other methods are sometimes used in special applications. These are the continuous-wave (cw) method and the frequency modulation (fm) method. All three basic transmission methods are often further subdivided to designate specific variations or combinations.

1.4.1 Continuous-Wave Method

When radio-frequency energy transmitted from a fixed point continuously strikes an object that is either moving toward or away from the source of the energy, the *frequency* of the reflected energy is changed. This shift in frequency is known as the DOPPLER EFFECT. The difference in frequency between the transmitted and reflected energy indicates both the presence and the speed of a moving target.

1.4.1.1 Doppler Effect

A common example of the Doppler effect in action is the changing pitch of the whistle of an approaching train. The whistle appears to change pitch from a high tone, as the train approaches, to a lower tone as it moves away from the observer. As the train approaches, an apparent increase in frequency (an increase in pitch) is heard; as the train moves away, an apparent decrease in frequency (a decrease in pitch) is heard. This pitch variation is known as the Doppler effect.

Let's examine the reason for this apparent change in pitch. Assume that the transmitter emits an audio signal at a frequency of 60 hertz and that the transmitter is traveling at a velocity of 360 feet per second (fps). At the end of 1 second, the transmitter will have moved from point P to point P1 as shown in view A of figure 1-20. The total distance from point P to the observer is 1,080 feet. The velocity of sound is 1,080 feet per second; thus, a sound emitted at point P will reach the observer in 1 second. To find the wavelength of this transmitted signal, you divide the velocity of the signal (1,080 fps) by the frequency (60 hertz). The result is 18 feet, as shown below:

NEETS MODULE 18-Radar Principles

$$\begin{aligned} \text{wavelength} &= \frac{\text{velocity}}{\text{frequency}} \\ &= \frac{1,080 \text{ fps}}{60 \text{ Hz}} \\ &= 18 \text{ feet} \end{aligned}$$

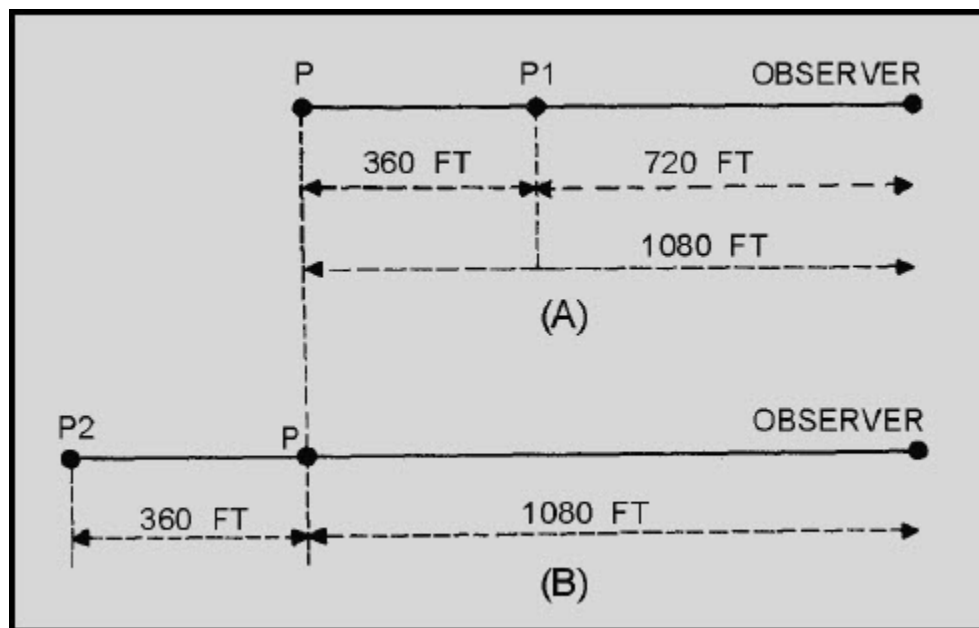

Figure 1-20 Transmitter moving relative to an observer

In 1 second the transmitter moves 360 feet and transmits 60 hertz. At the end of 1 second, the first cycle of the transmitted signal reaches the observer, just as the sixtieth cycle is leaving the transmitter at point P1. Under these conditions the 60 hertz emitted is located between the observer and point P1. Notice that this distance is only 720 feet (1,080 minus 360). The 60 hertz is spread over the distance from point P1 to the observer and has a wavelength of just 12 feet (720 divided by 60). To find the new frequency, use the following formula:

NEETS MODULE 18-Radar Principles

$$\begin{aligned} \text{frequency} &= \frac{\text{velocity}}{(\text{wavelength})} \\ &= \frac{1,080}{12} \\ &= 90 \text{ hertz} \end{aligned}$$

The original frequency, 60 hertz, has changed to an apparent frequency of 90 hertz. This new frequency only applies to the observer. Notice that the Doppler frequency variation is directly proportional to the velocity of the approaching transmitter. The faster the transmitter moves toward the observer, the greater the number of waves that will be crowded into the space between the transmitter and the observer.

Suppose the transmitter were stationary and the observer moving. When approaching the transmitter, the observer would encounter waves per unit of time. As a result, the observer would hear a higher pitch than the transmitter would actually emit.

If the transmitter were traveling away from the observer, as shown in view B of figure 1-20, the first cycle would leave the transmitter at point P and the sixtieth at point P2. The first cycle would reach the observer when the transmitter reached P2. You would then have 60 cycles stretched out over 1,080 plus 360 feet, a total of 1,440 feet. The wavelength of these 60 hertz is 1,440/60, or 24 feet. The apparent frequency is 1,080 divided by 24, or 45 hertz.

1.4.1.2 Uses of CW Doppler System

The continuous-wave, or Doppler, system is used in several ways. In one radar application, the radar set differentiates between the transmitted and reflected wave to determine the speed of the moving object.

The Doppler method is the best means of detecting fast-moving objects that do not require range resolution. As a moving object approaches the transmitter, it encounters and reflects more waves per unit of time. The amount of frequency shift produced is very small in relation to the carrier frequency. This is because the velocity of propagation of the signal is very high compared to the speed of the target. However, because the carrier frequencies used in radar are high, larger frequency shifts (in the audio frequency range) are produced. The *amount* of shift is proportional to the *speed* of the reflecting object. One-quarter cycle shift at 10,000 megahertz will provide speed measurements accurate to a fraction of a percent.

NEETS MODULE 18-Radar Principles

If an object is moving, its velocity, relative to the radar, can be detected by comparing the transmitter frequency with the echo frequency (which differs because of the Doppler shift). The DIFFERENCE or BEAT FREQUENCY, sometimes called the DOPPLER FREQUENCY (f_d), is related to object velocity.

The separation of the background and the radar contact is based on the Doppler frequency that is caused by the reflection of the signal from a moving object. Disadvantages of the Doppler system are that it does not determine the range of the object, nor is it able to differentiate between objects when they lie in the same direction and are traveling at the same speed. Moreover, it does not "see" stationary or slow moving objects, which a pulse radar system can detect.

To track an object with cw Doppler, you must determine the radar range. Since the Doppler frequency is not directly related to range, another method is needed to determine object range. By using two separate transmitters that operate at two different frequencies (f_1 and f_2), you can determine range by measuring the relative phase difference between the two Doppler frequencies. In such a system, a mixer is used to combine the two transmitted frequencies and to separate the two received frequencies. This permits the use of one transmitting and receiving antenna.

Instead of using two transmitter frequencies, you can find the range by sweeping the transmitter frequency uniformly in time to cover the frequency range from f_1 to f_2 . The beat, or difference, frequency between the transmitted and received signals is then a function of range. In this type of radar, the velocity as well as range is measured.

Q24. The Doppler effect causes a change in what aspect of rf energy that strikes a moving object?

Q25. The Doppler variation is directly proportional to what radar contact characteristic?

Q26. The Doppler method of object detection is best for what type objects?

Q27. The beat frequency in a swept-frequency transmitter provides what contact information?

NEETS MODULE 18-Radar Principles

1.4.2 Frequency-Modulation Method

In the frequency-modulation method, the transmitter radiates radio-frequency waves. The frequency of these rf waves is continually increasing and decreasing from a fixed reference frequency. At any instant, the frequency of the returned signal differs from the frequency of the radiated signal. The amount of the difference frequency is determined by the time it took the signal to travel the distance from the transmitter to the object.

An example of a frequency-modulated signal, plotted against time, is shown in figure 1-21. As shown, the 420-megahertz frequency increases linearly to 460 megahertz and then quickly drops to 420 megahertz again. When the frequency drops to 420 megahertz the frequency cycle starts over again.

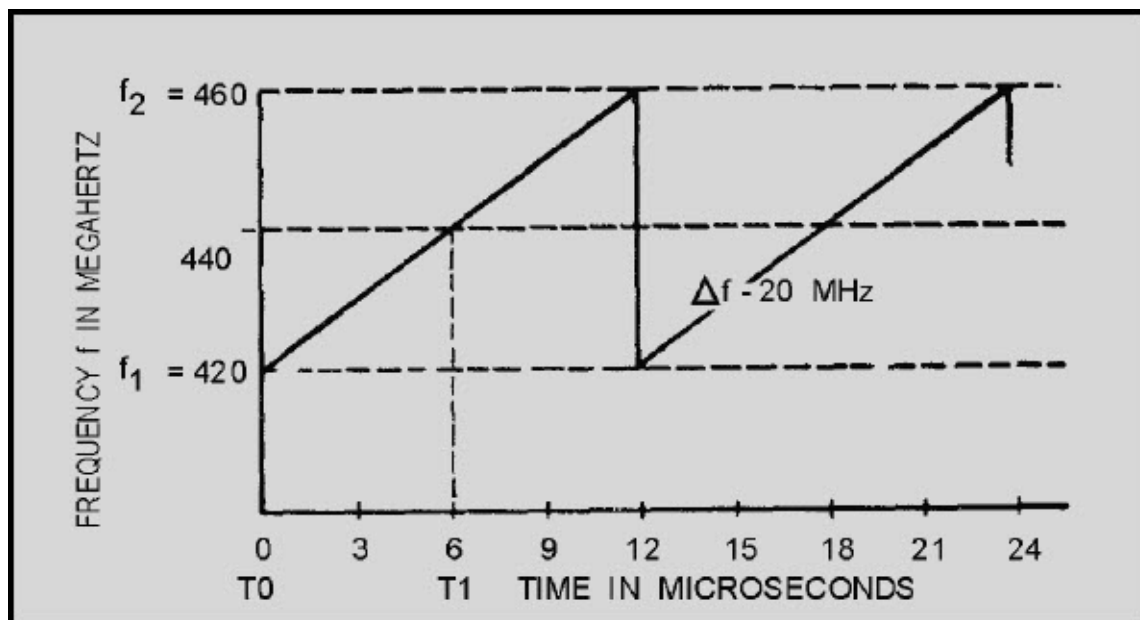

Figure 1-21 Frequency-modulation chart

The frequency regularly changes 40 megahertz with respect to time; therefore, its value at any time during its cycle can be used as the basis for computing the time elapsed after the start of the frequency cycle. For example, at T0 the transmitter sends a 420-megahertz signal toward an object. It strikes the object and returns to the receiver at T1, when the transmitter is sending out a new frequency of 440 megahertz. At T1, the 420-megahertz returned signal and the 440-megahertz transmitter signal are fed to the receiver simultaneously. When the two signals are mixed in the receiver, a beat frequency results. The beat frequency varies directly with the distance to the object, increasing as the distance increases. Using this information, you can calibrate a device that measures frequency to indicate range.

NEETS MODULE 18-Radar Principles

This system works well when the detected object is stationary. It is used in aircraft altimeters which give a continuous reading of the height above the earth of the aircraft. The system is not satisfactory for locating moving objects. This is because moving targets produce a frequency shift in the returned signal because of the Doppler effect; this affects the accuracy of the range measurement.

1.4.3 Pulse-Modulation Method

The pulse-modulation method of energy transmission was analyzed to some extent earlier in this chapter. As the previous discussions indicated, radio-frequency energy can also be transmitted in very short bursts, called pulses. These pulses are of extremely short time duration, usually on the order of 0.1 microsecond to approximately 50 microseconds. In this method, the transmitter is turned on for a very short time and the pulse of radio-frequency energy is transmitted, as shown in view A of figure 1-22. The transmitter is then turned off, and the pulse travels outward from the transmitter at the velocity of light (view B). When the pulse strikes an object (view C), it is reflected and begins to travel back toward the radar system, still moving at the same velocity (view D). The pulse is then received by the radar system (view E). The time interval between transmission and reception is computed and converted into a visual indication of range in miles or yards. The radar cycle then starts over again by transmitting another pulse (view F). This method does not depend on the relative frequency of the returned signal or on the motion of the target; therefore, it has an important advantage over cw and fm methods.

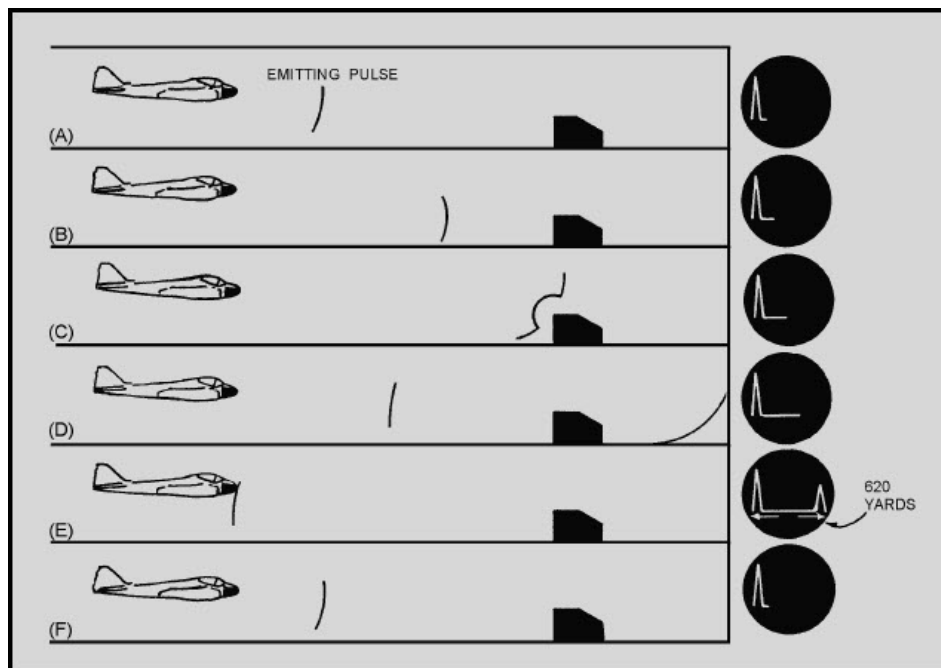

Figure 1-22 Pulse detection

NEETS MODULE 18-Radar Principles

1.4.4 Pulse-Doppler Method

Pulse radar systems may be modified to use the Doppler effect to detect a moving object.

A requirement for any Doppler radar is COHERENCE; that is, some definite phase relationship must exist between the transmitted frequency and the reference frequency, which is used to detect the Doppler shift of the receiver signal. Moving objects are detected by the phase difference between the target signal and background noise components. Phase detection of this type relies on coherence between the transmitter frequency and the receiver reference frequency.

In coherent detection, a stable cw reference oscillator signal, which is locked in phase with the transmitter during each transmitted pulse, is mixed with the echo signal to produce a beat or difference signal. Since the reference oscillator and the transmitter are locked in phase, the echoes are effectively compared with the transmitter in frequency and phase.

The phase relationships of the echoes from fixed objects to the transmitter is constant and the amplitude of the beat signal remains constant. A beat signal of varying amplitude indicates a moving object. This is because the phase difference between the reference oscillator signal and the echo signal changes as the range to the reflecting object changes. The constant amplitude beat signal is filtered out in the receiver. The beat signal of varying amplitude is sent to the radar indicator scope for display.

Q28. What factor determines the difference between the transmitted frequency and the received frequency in an fm transmitter?

Q29. What type of objects are most easily detected by an fm system?

Q30. What transmission method does NOT depend on relative frequency or target motion?

Q31. What transmission method uses a stable cw reference oscillator, which is locked in phase with the transmitter frequency?

NEETS MODULE 18-Radar Principles

1.5 RADAR CLASSIFICATION AND USE

Radar systems, like cars, come in a variety of sizes and have different performance specifications. Some radar systems are used for air-traffic control at airports and others are used for long-range surveillance and early-warning systems. A radar system is the heart of a missile guidance system. Small portable radar systems that can be maintained and operated by one person are available as well as systems that occupy several large rooms.

1.5.1 Military Classification of Radar Systems

The large number of radar systems used by the military has forced the development of a joint services classification system for accurate identification. The Federal Aviation Agency (FAA) also makes extensive use of radar systems for commercial aircraft in-flight and landing control, but does not use the military classification system.

Radar systems are usually classified according to specific function and installation vehicle. Some common examples are listed below:

FUNCTION	INSTALLATION VEHICLE
Search	Ground or land based
Track	Airborne
Height-finder	Shipboard

The joint-service standardized classification system further divides these broad categories for more precise identification. Table 1-1 is a listing of equipment identification indicators. Use of the table to identify a particular radar system is illustrated in figure 1-23. Note that for simplicity, only a portion of the table has been used in the illustration.

NEETS MODULE 18-Radar Principles

TABLE OF EQUIPMENT INDICATORS			Miscellaneous Identification
Installation (1st letter)	Type of Equipment (2d letter)	Purpose (3rd letter)	
A—Piloted aircraft	A—invisible light, heat radiation	B—Bombing	X, Y, Z—Changes in voltage, phase, or frequency T—Training (V)—Variable grouping
B—Underwater mobile, submarine D—Pilotless carrier	C—Carrier D—Radic	C—Communications (receiving and transmitting) D—Direction finder reconnaissance and/or surveillance	
F—Fixed ground G—General ground use	G—Telegraph or Teletype I—Interphone and public address	E—Ejection and/or release G—Fire control, or search-light directing	
K—Amphibious	J—Electromechanical or Inertial wire covered	H—Recording and/or reproducing (graphic meteorological and sound)	
M—Ground, mobile P—Portable	K—Telemetry L—Countermeasures	K—Computing M—Maintenance and/or test assemblies (including tools)	
S—Water	M—Meteorological	N—Navigational aids (including altimeters, beacons, compasses, racons, depth sounding, approach and landing)	
T—Ground, transportable	N—Sound in air	Q—Special, or combination of purposes	
U—General utility	P—Radar	R—Receiving, passive detecting	
V—Ground, vehicular	Q—Sonar and underwater sound	S—Detecting and/or range and bearing, search	
W—Water surface and under water combination Z—Piloted and pilotless airborne vehicle combination	R—Radio	T—Transmitting	
	S—Special types, magnetic, etc., or combinations of types T—Telephone (wire)	W—Automatic flight or remote control	
	V—Visual and visible light	X—Identification and recognition Y—Surveillance (search detect, and multiple target tracking) and control (both fire control and air control)	
	W—Armament (peculiar to armament, not otherwise covered)		
	X—Facsimile or television Y—Data processing	X—Facsimile or television	

NEETS MODULE 18-Radar Principles

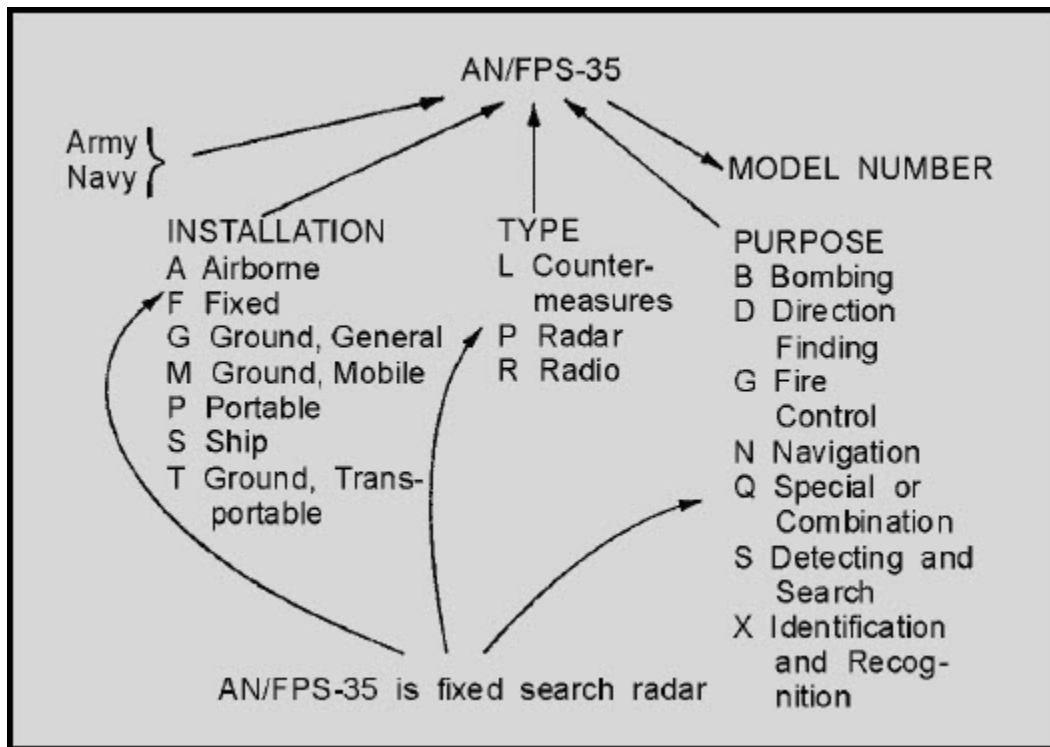

Figure 1-23 Joint service classification system

1.5.2 Radar Functions

No single radar system has yet been designed that can perform all of the many radar functions required by the military. Some of the newer systems combine several functions that formerly required individual radar systems, but no single system can fulfill all the requirements of modern warfare. As a result, modern warships, aircraft, and shore stations usually have several radar systems, each performing a different function.

One radar system, called SEARCH RADAR, is designed to continuously scan a volume of space to provide initial detection of all targets. Search radar is almost always used to detect and determine the position of new targets for later use by TRACK RADAR. Track radar provides continuous range, bearing, and elevation data on one or more targets. Most of the radar systems used by the military are in one of these two categories, though the individual radar systems vary in design and capability.

NEETS MODULE 18-Radar Principles

Some radar systems are designed for specific functions that do not precisely fit into either of the above categories. The radar speed gun is an example of radar designed specifically to measure the speed of a target. The military uses much more complex radar systems that are adapted to detect only fast moving targets such as aircraft. Since aircraft usually move much faster than weather or surface targets, velocity-sensitive radar can eliminate unwanted clutter from the radar indicator. Radar systems that detect and process only moving targets are called MOVING-TARGET INDICATORS (mti) and are usually combined with conventional search radar.

Another form of radar widely used in military and civilian aircraft is the RADAR ALTIMETER. Just as some surface-based radars can determine the height of a target, airborne radar can determine the distance from an aircraft to the ground. Many aircraft use radar to determine height above the ground. Radar altimeters usually use frequency-modulated signals of the type discussed earlier in the chapter.

1.6 RADAR TYPES

The preceding paragraphs indicated that radar systems are divided into types based on the designed use. This section presents the general characteristics of several commonly used radar systems. Typical characteristics are discussed rather than the specific characteristics of any particular radar system.

1.6.1 Search Radar

Search radar, as previously mentioned, continuously scans a volume of space and provides initial detection of all targets within that space. Search radar systems are further divided into specific types, according to the type of object they are designed to detect. For example, surface-search, air-search, and height-finding radars are all types of search radar.

1.6.1.1 Surface-Search Radar

A surface-search radar system has two primary functions: (1) the detection and determination of accurate ranges and bearings of surface objects and low-flying aircraft and (2) the maintenance of a 360-degree search pattern for all objects within line-of-sight distance from the radar antenna.

NEETS MODULE 18-Radar Principles

The maximum range ability of surface-search radar is primarily limited by the radar horizon; therefore, higher frequencies are used to permit maximum reflection from small, reflecting areas, such as ship masthead structures and the periscopes of submarines. Narrow pulse widths are used to permit a high degree of range resolution at short ranges and to achieve greater range accuracy. High pulse-repetition rates are used to permit a maximum definition of detected objects. Medium peak power can be used to permit the detection of small objects at line-of-sight distances. Wide vertical-beam widths permit compensation for the pitch and roll of own ship and detection of low flying aircraft. Narrow horizontal beam widths permit accurate bearing determination and good bearing resolution. For example, a common shipboard surface-search radar has the following design specifications:

- Transmitter frequency 5,450-5,825 MHz
- Pulse width .25 or 1.3 microseconds
- Pulse-repetition rate between 625 and 650 pulses per second
- Peak power between 190 and 285 kW
- Vertical beam width between 12 and 16 degrees
- Horizontal beam width 1.5 degrees

Surface-search radar is used to detect the presence of surface craft and low flying aircraft and to determine their presence. Shipboard surface-search radar provides this type of information as an input to the weapons system to assist in the engagement of hostile targets by fire-control radar. Shipboard surface search radar is also used extensively as a navigational aid in coastal waters and in poor weather conditions. A typical surface-search radar antenna is shown in figure 1-24.

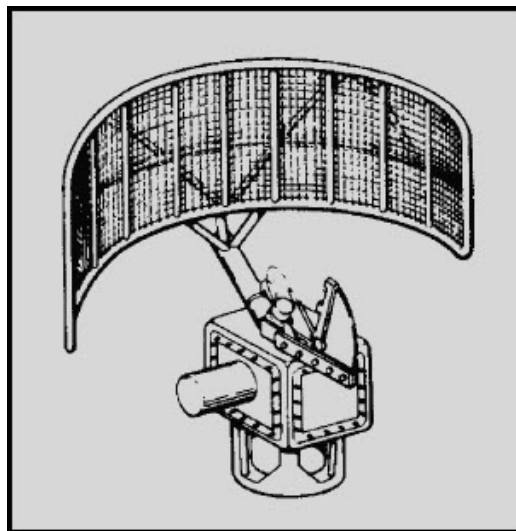

Figure 1-24 Surface-search radar

NEETS MODULE 18-Radar Principles

Q32. What type of radar provides continuous range, bearing, and elevation data on an object?

Q33. Radar altimeters use what type of transmission signal?

Q34. A surface-search radar normally scans how many degrees of azimuth?

Q35. What limits the maximum range of a surface-search radar?

Q36. What is the shape of the beam of a surface-search radar?

1.6.1.2 Air-Search Radar

Air-search radar systems initially detect and determine the position, course, and speed of air targets in a relatively large area. The maximum range of air-search radar can exceed 300 miles, and the bearing coverage is a complete 360-degree circle. Air-search radar systems are usually divided into two categories, based on the amount of position information supplied. As mentioned earlier in this chapter, radar sets that provide only range and bearing information are referred to as two-dimensional, or 2D, radars. Radar sets that supply range, bearing, and height are called three-dimensional, or 3D, radars. (3D radar will be covered in the next section.) The coverage pattern of a typical 2D radar system is illustrated in figure 1-25. A typical 2D air-search radar antenna is shown in figure 1-26.

NEETS MODULE 18-Radar Principles

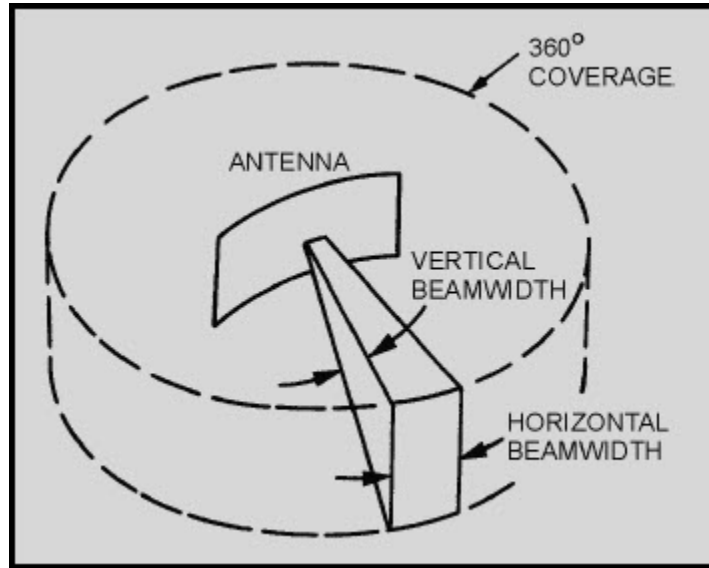

Figure 1-25 2D radar coverage pattern

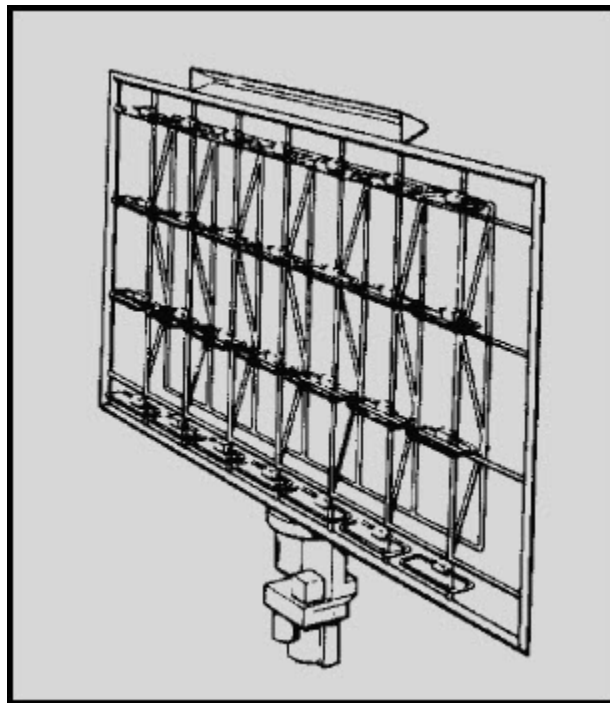

Figure 1-26 2D air-search radar

NEETS MODULE 18-Radar Principles

Relatively low transmitter frequencies are used in 2D search radars to permit long-range transmissions with minimum attenuation. Wide pulse widths and high peak power are used to aid in detecting small objects at great distances. Low pulse-repetition rates are selected to permit greater maximum range. A wide vertical-beam width is used to ensure detection of objects from the surface to relatively high altitudes and to compensate for pitch and roll of own ship. The output characteristics of specific air-search radars are classified; therefore, they will not be discussed.

Air-search radar systems are used as early-warning devices because they can detect approaching enemy aircraft or missiles at great distances. In hostile situations, early detection of the enemy is vital to a successful defense against attack. Antiaircraft defenses in the form of shipboard guns, missiles, or fighter planes must be brought to a high degree of readiness in time to repel an attack. Range and bearing information, provided by air-search radars, used to initially position a fire-control tracking radar on a target. Another function of the air-search radar system is guiding combat air patrol (CAP) aircraft to a position suitable to intercept an enemy aircraft. In the case of aircraft control, the guidance information is obtained by the radar operator and passed to the aircraft by either voice radio or a computer link to the aircraft.

1.6.1.3 Height-Finding Search Radar

The primary function of a height-finding radar (sometimes referred to as a three-coordinate or 3D radar) is that of computing accurate ranges, bearings, and altitudes of aircraft targets detected by air search radars. Height-finding radar is also used by the ship's air controllers to direct CAP aircraft during interception of air targets. Modern 3D radar is often used as the primary air-search radar (figure 1-27). This is because of its high accuracy and because the maximum ranges are only slightly less than those available from 2D radar.

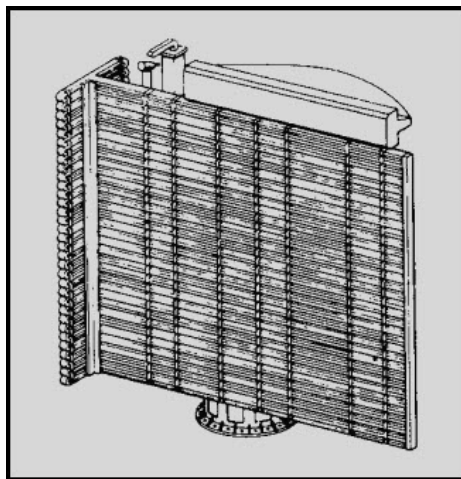

Figure 1-27 3D air-search radar

NEETS MODULE 18-Radar Principles

The range capability of 3D search radar is limited to some extent by an operating frequency that is higher than that of 2D radar. This disadvantage is partially offset by higher output power and a beamwidth that is narrower in both the vertical and horizontal planes.

The 3D radar system transmits several narrow beams to obtain altitude coverage and, for this reason, compensation for roll and pitch must be provided for shipboard installations to ensure accurate height information.

Applications of height-finding radars include the following:

- Obtaining range, bearing, and altitude data on enemy aircraft and missiles to assist in the control of CAP aircraft
- Detecting low-flying aircraft
- Determining range to distant land masses
- Tracking aircraft over land
- Detecting certain weather phenomena
- Tracking weather balloons
- Providing precise range, bearing, and height information for fast, accurate initial positioning of fire-control tracking radars

Q37. Air-search radar is divided into what two basic categories?

Q38. What position data are supplied by 2D search radar?

Q39. Why do 2D air-search radars use relatively low carrier frequencies and low pulse-repetition rates?

Q40. Why is the range capability of 3D radar usually less than the range of 2D radar?

NEETS MODULE 18-Radar Principles

1.6.2 Tracking Radar

Radar that provides continuous positional data on a target is called tracking radar. Most tracking radar systems used by the military are also fire-control radar; the two names are often used interchangeably.

Fire-control tracking radar systems usually produce a very narrow, circular beam.

Fire-control radar must be directed to the general location of the desired target because of the narrow-beam pattern. This is called the DESIGNATION phase of equipment operation. Once in the general vicinity of the target, the radar system switches to the ACQUISITION phase of operation. During acquisition, the radar system searches a small volume of space in a prearranged pattern until the target is located. When the target is located, the radar system enters the TRACK phase of operation. Using one of several possible scanning techniques, the radar system automatically follows all target motions. The radar system is said to be *locked on* to the target during the track phase. The three sequential phases of operation are often referred to as MODES and are common to the target-processing sequence of most fire control radars.

Typical fire-control radar characteristics include a very high prf, a very narrow pulse width, and a very narrow beam width. These characteristics, while providing extreme accuracy, limit the range and make initial target detection difficult. A typical fire-control radar antenna is shown in figure 1-28. In this example the antenna used to produce a narrow beam is covered by a protective radome.

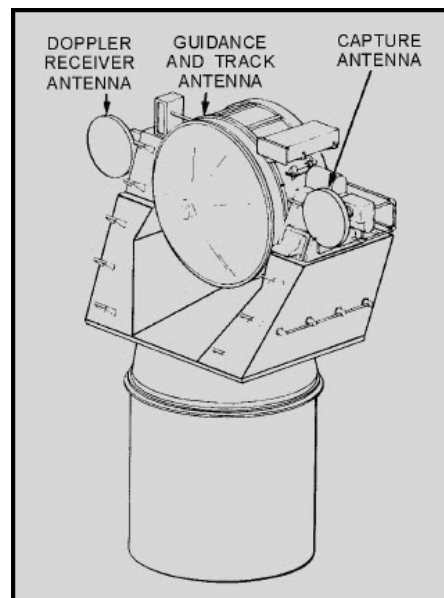

Figure 1-28 Fire-control radar

NEETS MODULE 18-Radar Principles

1.6.3 Missile-Guidance Radar

A radar system that provides information used to guide a missile to a hostile target is called GUIDANCE RADAR. Missiles use radar to intercept targets in three basic ways: (1) Beam-rider missiles follow a beam of radar energy that is kept continuously pointed at the desired target; (2) homing missiles detect and home in on radar energy reflected from the target; the reflected energy is provided by a radar transmitter either in the missile or at the launch point and is detected by a receiver in the missile; (3) passive homing missiles home in on energy that is radiated by the target. Because target position must be known at all times, a guidance radar is generally part of, or associated with, a fire-control tracking radar. In some instances, three radar beams are required to provide complete guidance for a missile. The beam riding missile, for example, must be launched into the beam and then must ride the beam to the target. Initially, a wide beam is radiated by a capture radar to gain (capture) control of the missile. After the missile enters the capture beam, a narrow beam is radiated by a guidance radar to guide the missile to the target. During both capture and guidance operations, a tracking radar continues to track the target. Figure 1-29 illustrates the relationships of the three different radar beams.

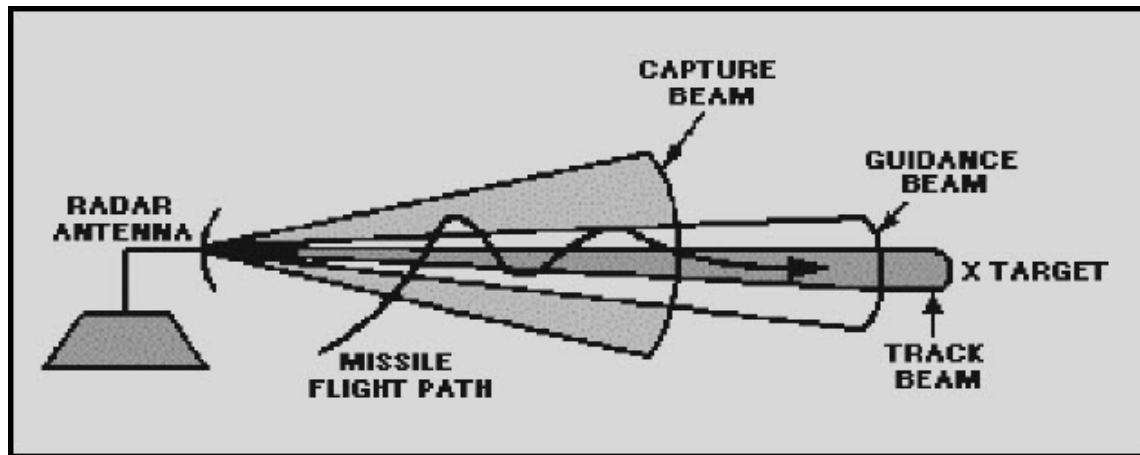

Figure 1-29 Beam relationship of capture, guidance, and track beams

Q41. Fire-control tracking radar most often radiates what type of beam?

Q42. Tracking radar searches a small volume of space during which phase of operation?

Q43. What width is the pulse radiated by fire-control tracking radar?

NEETS MODULE 18-Radar Principles

Q44. Which beam of missile-guidance radar is very wide?

1.6.4 Carrier-Controlled Approach (CCA) and Ground-Controlled Approach (GCA Radar)

CARRIER-CONTROLLED APPROACH and GROUND-CONTROLLED APPROACH radar systems are essentially shipboard and land-based versions of the same type of radar. Shipboard CCA radar systems are usually much more sophisticated systems than GCA systems. This is because of the movements of the ship and the more complicated landing problems. Both systems, however, guide aircraft to safe landing under conditions approaching zero visibility. By means of radar, aircraft are detected and observed during the final approach and landing sequence. Guidance information is supplied to the pilot in the form of verbal radio instructions, or to the automatic pilot (autopilot) in the form of pulsed control signals.

1.6.5 Airborne Radar

Airborne radar is designed especially to meet the strict space and weight limitations that are necessary for all airborne equipment. Even so, airborne radar sets develop the same peak power as shipboard and shore-based sets.

As with shipboard radar, airborne radar sets come in many models and types to serve many different purposes. Some of the sets are mounted in blisters (or domes) that form part of the fuselage; others are mounted in the nose of the aircraft.

In fighter aircraft, the primary mission of a radar is to aid in the search, interception, and destruction of enemy aircraft. This requires that the radar system have a tracking feature. Airborne radar also has many other purposes. The following are some of the general classifications of airborne radar: search, intercept and missile control, bombing, navigation, and airborne early warning.

1.7 SUMMARY

The following paragraphs summarize the important points of this chapter.

RADAR is an electronic system that uses reflected electromagnetic energy to detect the presence and position of objects invisible to the eye.

TARGET POSITION is defined in reference to true north, the horizontal plane, and the vertical plane.

NEETS MODULE 18-Radar Principles

TRUE BEARING is the angle between true north and the line of sight to the target, measured in a clockwise direction in the horizontal plane.

ELEVATION ANGLE is the angle between the horizontal plane and the line of sight, measured in the vertical plane.

RANGE is the distance from the radar site to the target measured along the line of sight.

RANGE to any target can be calculated by measuring the time required for a pulse to travel to a target and return to the radar receiver and by dividing the elapsed time by 12.36 microseconds.

The **MAXIMUM RANGE** of a pulse radar system depends on the **CARRIER FREQUENCY**, **PEAK POWER**, **PULSE-REPETITION FREQUENCY**, and **RECEIVER SENSITIVITY**.

PULSE-REPETITION TIME is the time between the beginning of one pulse and the beginning of the next pulse and is the reciprocal of prf.

AMBIGUOUS RETURNS are echoes from targets that exceed the prt of the radar system and result in false range readings.

The **PEAK POWER** of a radar system is the total energy contained in a pulse. Peak power is obtained by multiplying the maximum power level of a pulse by the pulse width.

Since most instruments are designed to measure **AVERAGE POWER** over a period of time, prt must be included in transmitter power measurements.

The product of pw and prf is called the **DUTY CYCLE** of a radar system and is the ratio of transmitter time on to time off.

Antenna height and **ROTATION SPEED** affect radar range. Since high-frequency energy does not normally bend to follow the curvature of the earth, most radar systems cannot detect targets below the **RADAR HORIZON**.

The slower an antenna rotates, the larger the **HITS PER SCAN** value. The likelihood that a target will produce a usable echo is also increased.

The bearing to a target may be referenced to true north or to your own ship. Bearing referenced to true north is **TRUE BEARING** and bearing referenced to your ship is **RELATIVE BEARING**, as shown in the illustration. The bearing angle is obtained by moving the antenna to the point of maximum signal return.

NEETS MODULE 18-Radar Principles

Radar systems that detect only range and bearing are called TWO-DIMENSIONAL (2D) radars. Radars that detect height as well as range and bearing are called THREE-DIMENSIONAL (3D) RADARS.

The target RESOLUTION of a radar system is its ability to distinguish between targets that are very close together.

RANGE RESOLUTION is the ability to distinguish between two or more targets on the same bearing and is primarily dependent on the pulse width of the radar system.

BEARING RESOLUTION is the ability of a radar to separate targets at the same range but different bearings. The degree of bearing resolution is dependent on beam width and range. The accuracy of radar is largely dependent on resolution.

ATMOSPHERIC CONDITIONS affect the speed and direction of travel of electromagnetic wavefronts traveling through the air. Under normal conditions, the wavefronts increase uniformly in speed as altitude increases which causes the travel path to curve downward. The downward curve extends the radar horizon as shown in the illustration. The density of the atmosphere, the presence of water vapor, and temperature changes also directly affect the travel of electromagnetic wavefronts.

The major components in a typical PULSE RADAR SYSTEM are shown in the illustration. The SYNCHRONIZER supplies the timing signals to coordinate the operation of the entire system. The TRANSMITTER generates electromagnetic energy in short, powerful pulses. The DUPLEXER allows the same antenna to be used to both transmit and receive. The RECEIVER detects and amplifies the return signals. The INDICATOR produces a visual indication of the range and bearing of the echo.

SCANNING is the systematic movement of a radar beam while searching for or tracking a target.

STATIONARY-LOBE SCANNING is the simplest type of scanning and is usually used in 2D search radar. Monopulse scanning, used in fire-control radars, employs four signal quantities to accurately track moving targets. The two basic methods of scanning are MECHANICAL and ELECTRONIC.

Radar systems are often divided into operational categories based on energy transmission methods—continuous wave (cw), frequency modulation (fm), and pulse modulation (pm).

NEETS MODULE 18-Radar Principles

The **CONTINUOUS WAVE (cw)** method transmits a constant frequency and detects moving targets by detecting the change in frequency caused by electromagnetic energy reflecting from a moving target. This change in frequency is called the **DOPPLER SHIFT** or **DOPPLER EFFECT**.

In the **FREQUENCY MODULATION (fm)** method, a signal that constantly changes in frequency around a fixed reference is used to detect stationary objects.

The **PULSE-MODULATION (pm) METHOD** uses short pulses of energy and relatively long listening times to accurately determine target range. Since this method does not depend on signal frequency or target motion, it has an advantage over cw and fm methods. It is the most common type of radar.

Radar systems are also classified by function. **SEARCH RADAR** continuously scans a volume of space and provides initial detection of all targets. **TRACK RADAR** provides continuous range, bearing, and elevation data on one or more specific targets. Most radar systems are variations of these two types.

NEETS MODULE 18-Radar Principles

ANSWERS TO QUESTIONS Q1. AND Q44.

- A1. *Horizontal plane.*
- A2. *Range.*
- A3. *Approximately the speed of light (162,000 nautical miles per second).*
- A4. *12.36 microseconds.*
- A5. *Pulse width.*
- A6. *Frequency.*
- A7.

$$\frac{1}{prt} = \text{prf}$$

- A8. *Average power.*
- A9. *Duty cycle.*
- A10. *Relative bearing.*
- A11. *Three-dimensional.*
- A12. *Frequency or phase.*
- A13. *Target resolution.*
- A14. *Beam width and range.*
- A15. *Speed increases.*
- A16. *Temperature inversion.*
- A17. *Synchronizer.*
- A18. *High-voltage pulse from the modulator.*

NEETS MODULE 18-Radar Principles

- A19. *Duplexer.*
- A20. *Single lobe.*
- A21. *The reflected signals decrease in strength.*
- A22. *Mechanical and electronic.*
- A23. *Nutation.*
- A24. *Frequency.*
- A25. *Velocity.*
- A26. *Fast-moving targets.*
- A27. *Range.*
- A28. *Travel time.*
- A29. *Stationary.*
- A30. *Pulse modulation.*
- A31. *Pulse-Doppler.*
- A32. *Track radar.*
- A33. *Frequency modulated (fm).*
- A34. *360 degrees.*
- A35. *Radar horizon.*
- A36. *Wide vertically, narrow horizontally.*
- A37. *2D and 3D.*
- A38. *Range and bearing.*
- A39. *Increased maximum range.*
- A40. *Higher operating frequency.*

NEETS MODULE 18-Radar Principles

A41. *A narrow circular beam.*

A42. *Acquisition.*

A43. *Very narrow.*

A44. *Capture beam.*